

DEPARTMENT OF THE ARMY TECHNICAL MANUAL

---

TECHNICAL MANUAL

OPERATOR, ORGANIZATIONAL,

DIRECT SUPPORT AND GENERAL SUPPORT

MAINTENANCE MANUAL

THEODOLITE: DIRECTIONAL;

5.9 IN. LG TELESCOPE; DETACHABLE TRIBRACH,

W/ACCESSORIES AND TRIPOD

(WILD HEERBRUGG MODEL T-16-0.2 MIL)

(FSN 6675-542-1683)

This copy is a reprint which includes current  
pages from Changes 2 through 5.

---

HEADQUARTERS, DEPARTMENT OF THE ARMY

31 MAY 1973

## WARNING

### Possible Eye Injury

Always use sunglasses when  
Looking directly at the sun  
to prevent eye injury.

## CAUTION

Prevent damage to equipment.

Exercise care when moving the  
tripod while instrument is mounted.

Never carry the theodolite over  
the shoulder. Always carry  
in a tilting position, with the  
tripod shoes to the rear.

**Do not use the hand lamp  
in close proximity to the compass.**

**Never touch polished metal surfaces.**

---

CHANGE }  
NO. 5 }

HEADQUARTERS  
DEPARTMENT OF THE ARMY  
WASHINGTON, D. C., 3 JUNE 1992

Operator's, Organizational, Direct Support, and  
General Support Maintenance Manual

THEODOLITE: DIRECTIONAL: 5.9 IN. LG TELESCOPE;  
DETACHABLE TRIBRACH, W/ACCESSORIES AND TRIPOD  
(WILD HEERBRUGG MODEL T-16-0.2 MIL)  
NSN 6675-00-542-1683

Approved for public release; distribution is unlimited.

TM 5-6675-200-14, 31 May 1973, is changed as follows:

Chg. 2. Page 1, Reporting of Errors, is superseded as follows:

**REPORTING OF ERRORS AND RECOMMENDING IMPROVEMENTS**

You can help improve this manual. If you find any mistakes or if you know of a way to improve the procedures, please let us know. Mail your letter, DA Form 2028 (Recommended Changes to Publications and Blank Forms), or DA Form 2028-2 located in the back of this manual direct to Commander, U.S. Army Troop Support Command, ATTN: AMSTR-MMTS, 4300 Goodfellow Boulevard, St. Louis, Missouri, 63120-1798. A reply will be furnished to you.

Page 1-1, second column, lines 1,2 & 3 are superseded as follows:

Commander, U.S. Army Troop Support Command, ATTN: AMSTR-MMTA, 4300 Goodfellow Boulevard, St. Louis, Missouri, 63120-1798.

Page 3 of Chg. 2 changes as follows: NSN'S and P/N's become:

Fig. 1-2 Item #6 6650-00-404-4400 XT16-112 Mirror assembly

Fig. 2-10 Item #s 4, 8, 9 6675-00-560-5649 XT16-113 Illumination light

**By Order of the Secretary of the Army:**

Official:

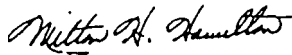

MILTON H. HAMILTON

Administrative Assistant to the  
Secretary of the Army

01610

GORDON R. SULLIVAN  
General, United States Army  
Chief of Staff

**DISTRIBUTION:**

To be distributed in accordance with DA Form 12-25E, qty rqr block no. 1828.

CHANGE }  
NO. 4 }

HEADQUARTERS  
DEPARTMENT OF THE ARMY  
WASHINGTON, D. C., 14 July 1989

Operator's, Organizational, Direct Support, and  
General Support Maintenance Manual

THEODOLITE: DIRECTIONAL; 5.9 IN. LG TELESCOPE;  
DETACHABLE TRI BRACH, W/ACCESSORIES AND TRIPOD  
(WILD HEERBRUGG MODEL T-16-0.2 MIL)  
NSN 6675-00-542-1683

Approved for public release; distribution is unlimited.

TM 5-6675-200-14, 31 May 1973, is changed as follows:

Page 2-13, paragraph 2-30a(2) is changed as follows:

"(2) Open the battery box (3), fig. 2-10.  
Remove the battery cable assembly (5), hand  
lamp assembly (6), and plug-in lamp reflector  
assembly (9). Inspect the batteries (1) for  
proper installation."

Page 2-13, Figure 2-10 Battery box and accessories, unpacked view, is changed  
as follows:

Delete dummy battery illustration (Item 2). Dummy batteries are no longer required.

Page 3, Section II, Integral Components of End Item, is changed as follows:

Delete Item 2, Battery, dummy, NSN 6135-00-937-4118, P/N EB329, FSCM (89905)

Appendix B, Section 111, Basic Issue Items, Item 6 changed as follows:

- a. Insert new National Stock Number: 5120-00-180-0729.
- b. Insert new Part No. and FSCM as follows: GGG-S-1808, Type I (89905).

**By Order of the Secretary of the Army:**

**C A R L E . V U O N O**  
*General, United States Army*  
*Chief of Staff*

**O f f i c i a l :**

WILLIAM J. MEEHAN, II  
*Brigadier General, United States Army*  
*The Adjutant General*

D I S T R I B U T I O N :

To be distributed in accordance with DA Form 12-25A, Operator, Unit, Direct Support  
and General Support Maintenance requirements for Theodolite, Directional, Detachable  
Tri bach, 5.9-In Telescope (T16-0.2 mil)

CHANGE }  
NO. 3 }

HEADQUARTERS  
DEPARTMENT OF THE ARMY  
WASHINGTON, D. C., 21 March 1988

Operator's, Organizational, Direct Support, and  
General Support Maintenance Manual

THEODOLITE: DIRECTIONAL; 5.9 IN. LG TELESCOPE;  
DETACHABLE TRI BRACH, W/ACCESSORIES AND TRI POD  
(WILD HEERBRUGG MODEL T-16-0.2 MIL)  
NSN 6675-00-542-1683

TM 5-6675-200-14, 31 May 1973, is changed as follows:

Table of Content Page, Reporting of Errors and Recommending Improvement block.  
Lines 4 and 5 are changed to read "Troop Support Command, ATTN: AMSTR-MCTS, 4300  
Goodfellow Blvd., St. Louis, MO 63120-1798.

Page 1-1, paragraph 1-2. "TM 38-750" is changed to read "DA Pamphlet 738-750".

Page A-1, Appendix A, paragraph A-4. Change "TM 38-750" to read "DA Pamphlet  
738.50".

Page B-1, Appendix B, Integral Component of End Item, figure 2-10, item numbers 4,  
8 and 9. Change NSN "6675-00-404-4400, P/N XT16-112" to read "6675-00-560-5649,  
P/N XT16-113".

Page E-1, Appendix E. Title is change to read "Expendable/Durable Supplies and  
Materials List".

Page E-1. Paragraph E-1 is superseded as follows:

E-1. Scope

This appendix lists expendable/durable supplies and materials  
you will need to operate and maintain the Theodolite. This  
listing is for information purposes only and is not authority  
to requisition the listed items. These items are authorized  
to you by CTA 50-970, Expendable/Durable Items (except Medical,  
Class V, Repair Parts and Heraldic Items), or CTA 8-100, Army  
Medical Department Expendable/Durable Items.

Page E-1. Appendix E, paragraph E-2 a, Last line is changed to read "Use cleaning  
compound, Item 5, App. E")."

Page 1-2, Index. Page and paragraph numbers for Illumination assembly, electrical  
is changed to read paragraph "2-30" and page "2-13".

**By Order of the Secretary of the Army:**

**CARL E. VUONO**  
*General, United States Army*  
*Chief of Staff*

**Official:**

**R. L. DILWORTH**  
*Brigadier General, United States Army*  
*The Adjutant General*

**DISTRIBUTION:**

To be distributed in accordance with DA Form 12-25A, Operator's, Unit, Direct Support and General Support Maintenance requirements for Theodolite, Directional, Detachable Tribach, 5.9-In Telescope (T16-0.2 mil).

Change }  
No. 2 }

HEADQUARTERS  
DEPARTMENT OF THE ARMY  
Washington, DC, 18 December 1978

**Operator's, Organizational, Direct Support, and  
General Support Maintenance Manual**

**THEODOLITE: DIRECTIONAL; 5.9 IN. LG TELESCOPE;  
DETACHABLE TRIBRACH, W/ACCESSORIES AND TRIPOD  
(WILD HEERBRUGG MODEL T-16-0.2 MIL)  
NSN 6675-00-542-1683**

TM 5-6675-200-14, 31 May 1973, is changed as follows:

Title page and table of contents page are changed as shown above.

**REPORTING OF ERRORS AND RECOMMENDING IMPROVEMENTS**

You can help improve this manual. If you find any mistakes or if you know of a way to improve the procedures, please let us know. Mail your letter, DA Form 2028 (Recommended Changes to Publications and Blank Forms), or DA Form 2028-2 located in the back of this manual direct to Commander, U.S. Army Troop Support and Aviation Materiel Readiness Command, ATTN: DRSTS-MTPS, 4300 Goodfellow Boulevard, St. Louis, Missouri, 63120. A reply will be furnished to you.

Page i. The appendices in the table of contents are superseded as follows:

- APPENDIX A. REFERENCES A-1
- B. COMPONENTS OF END ITEM LIST B-1
- C. ADDITIONAL AUTHORIZATION LIST C-1
- D. MAINTENANCE ALLOCATION CHART D-1
- E. EXPENDABLE SUPPLIES AND MATERIALS LIST E-1

Page 1-1, section I. Paragraph 1-3 is deleted in its entirety.

Page 3-5, section II. Paragraph 3-5 is superseded as follows:

3-5. Tools and Equipment

Integral components of and basic issue items for the theodolite are listed in Appendix B of this manual and TM 5-6675-200-25P.

Page B-1. Appendix B is superseded as follows:

**\*This change supersedes C1, 30 November 1976.**

APPENDIX B  
COMPONENTS OF END ITEM LIST

---

Section I. INTRODUCTION

**B-1. Scope**

This appendix lists integral components of and basic issue items for the theodolite to help you inventory items required for safe and efficient operation.

**B-2. General**

The Components of End Item List is divided into the following sections:

*a. Section II. Integral Components of the End Item.* These items, when assembled, comprise the theodolite and must accompany it whenever it is transferred or turned in. These illustrations will help you identify these items.

*b. Section III. Basic Issue Items.* These are minimum essential items required to place the theodolite in operation, to operate it, and to perform emergency repairs. Although shipped separately packed they must accompany the theodolite during operation and whenever it is transferred between accountable officers. The illustrations will assist you with hard-to-identify items. This manual is your authority to requisition replacement BII, based on table(s) of organization and equipment (TOE)/modification table of organization and equipment (MTOE) authorization of the end item.

**B-3. Explanation of Columns**

*a. Illustration* This column is divided as follows

(1) *Figure number.* Indicates the figure number of

the illustration on which the item is shown (if applicable).

(2) *Item number.* The number used to identify item called out in the illustration.

*b. National Stock Number (NSN).* Indicates the National stock number assigned to the item and which will be used for requisitioning.

*c. Part Number (P/N).* Indicates the primary number used by the manufacturer, which controls the design and characteristics of the item by means of its engineering drawings, specifications, standards, and inspection requirements to identify an item or range of items.

*d. Description.0* Indicates the Federal item name and if required, a minimum description to identify the item.

*e. Location.* The physical location of each item listed is given in this column. The lists are designed to inventory all items in one area of the major item before moving on to an adjacent area,

*f. Usable on Code.* Not Applicable

*g. Quantity Required (Qty Reqd).* This column lists the quantity of each item required for a complete major item.

*h. Quantity.* This column is left blank for use during inventory. Under the Rcv'd column, list the quantity you actually receive on your major item. The Date columns are for use when you inventory the major item at a later date, such as for shipment to another site.



Section II. INTEGRAL COMPONENTS OF END ITEM

| (1)<br>Illustration  |                    | (2)                         | (3)                       | (4)  | (5)      | (6)                  | (7)         | (8)<br>Quantity |      |      |      |
|----------------------|--------------------|-----------------------------|---------------------------|--|----------|----------------------|-------------|-----------------|------|------|------|
| (a)<br>Figure<br>No. | (b)<br>Item<br>No. | National<br>Stock<br>Number | Part No.<br>&<br>FSCM     | Description                                      | Location | Usable<br>on<br>Code | Qty<br>Reqd | Rev'd           | Date | Date | Date |
| 1-4                  | 9                  | 6675-01-036-2224            | XT16-121<br>(89905)       | Tribrach   |          |                      | 1           |                 |      |      |      |
| No callout           |                    | 6675-01-560-5462            | T16-720<br>(89905)        | Sunshade   |          |                      | 1           |                 |      |      |      |
| 1-2                  | 6                  | 6650-00-997-4334            | T16-4700<br>(89905)       | Mirror assembly,<br>circle illumination          |          |                      | 1           |                 |      |      |      |
| 2-6                  |                    | 6675-01-036-2225            | XT16-108<br>(89905)       | Case assembly,<br>carrying w/base                |          |                      | 1           |                 |      |      |      |
| 2-3                  | 5                  | 6675-00-830-8689            | NT1-893<br>(89905)        | Desiccant container                              |          |                      | 1           |                 |      |      |      |
| 3-1                  |                    | 6675-00-069-6059            | NT1-517<br>(89905)        | Case, shipping                                   |          |                      | 1           |                 |      |      |      |
| 2-7                  |                    |                             |                           | Case accessory con-<br>taining following:        |          |                      | 1           |                 |      |      |      |
| 2-7                  | 1                  | 6675-00-560-5472            | T16-761<br>(89905)        | Case accessory                                   |          |                      | 1           |                 |      |      |      |
| 2-7                  | 2                  | 6675-00-378-9401            | NT2-549<br>(89905)        | Cover, Theodolite                                |          |                      | 1           |                 |      |      |      |
| 2-7                  | 7                  | 6675-00-887-5561            | XT16-118<br>(89905)       | Compass assembly                                 |          |                      | 1           |                 |      |      |      |
| 2-7                  | 10                 | 6675-00-560-5587            | XT16-117<br>(89905)       | Eyepiece diagonal,<br>microscope                 |          |                      | 1           |                 |      |      |      |
| 2-7                  | 11                 | 6675-00-560-5586            | XT16-115A<br>(89905)      | Eyepiece diagonal,<br>telescope                  |          |                      | 1           |                 |      |      |      |
| 2-7                  | 13                 | 6650-00-624-3686            | XT2-92<br>(89905)         | Lens, telescope, black                           |          |                      | 1           |                 |      |      |      |
| 2-7                  | 12                 | 6675-00-446-1768            | XT16-116A<br>(89905)      | Sunglass assembly                                |          |                      | 1           |                 |      |      |      |
| 2-10                 |                    |                             |                           | Battery box assembly<br>containing following:    |          |                      | 1           |                 |      |      |      |
| 2-10                 | 3                  | 6675-01-036-5760            | EB319B<br>(89905)         | Box assembly, Battery                            |          |                      | 1           |                 |      |      |      |
| 2-10                 | 2                  | 6135-00-937-4118            | EB329<br>(89905)          | Battery, dummy                                   |          |                      | 2           |                 |      |      |      |
| 2-10                 | 4, 6<br>7          | 6675-00-997-4335            | GEB1-00000-<br>66 (89905) | Handlamp assembly<br>w/lamp                      |          |                      | 1           |                 |      |      |      |
| 2-10                 | 5                  | 6150-00-378-9500            | XT2-72<br>(89905)         | Cable assembly,<br>battery                       |          |                      | 1           |                 |      |      |      |
| 2-10                 | 4, 8<br>9          | 6675-00-404-4400            | XT16-112<br>(89905)       | Illumination light<br>assembly, w/lamp<br>holder |          |                      | 1           |                 |      |      |      |
| 3-4                  |                    | 6675-00-023-5052            | ADS1-2A<br>(89905)        | Haversack  |          |                      | 1           |                 |      |      |      |

Section II. INTEGRAL COMPONENTS OF END ITEM (cont)

| (1)<br>Illustration |                 | (2)<br>National Stock Number | (3)<br>Part No. & FSCM | (4)<br>Description                            | (5)<br>Location | (6)<br>Usable on Code | (7)<br>Qty Reqd | (8)<br>Quantity |      |      |      |
|---------------------|-----------------|------------------------------|------------------------|---|-----------------|-----------------------|-----------------|-----------------|------|------|------|
| (a)<br>Figure No.   | (b)<br>Item No. |                              |                        |   |                 |                       |                 | Rcv'd           | Date | Date | Date |
| 2-4                 |                 | 6675-00-641-3572             | IIIB (89905)           | Tripod assembly, extension leg consisting of: |                 |                       | 1               |                 |      |      |      |
| 2-4                 | 2               | 6675-00-641-3572             | 21B (89905)            | Tripod assembly                               |                 |                       | 1               |                 |      |      |      |
| 2-4                 | 7               | 6675-00-378-9525             | 3A63 (89905)           | Cover, tripod                                 |                 |                       | 1               |                 |      |      |      |
| 2-4                 | 6               | 6675-00-966-5793             | 3B35A36 (89905)        | Tripod accessory case                         |                 |                       | 1               |                 |      |      |      |
| 2-5                 | 3               | 5120-00-429-2949             | 3A29 (89905)           | Wrench, tripod                                |                 |                       | 1               |                 |      |      |      |
| 2-5                 | 2               | 5210-00-238-3299             | XT2-35 (89905)         | Plumb bob assembly w/adjuster                 |                 |                       | 1               |                 |      |      |      |

Section III. BASIC ISSUE ITEMS

| (1)<br>Illustration |                 | (2)<br>National Stock Number | (3)<br>Part No. & FSCM | (4)<br>Description  | (5)<br>Location | (6)<br>Usable on Code | (7)<br>Qty Reqd | (8)<br>Quantity |      |      |      |
|---------------------|-----------------|------------------------------|------------------------|---|-----------------|-----------------------|-----------------|-----------------|------|------|------|
| (a)<br>Figure No.   | (b)<br>Item No. |                              |                        |   |                 |                       |                 | Rcv'd           | Date | Date | Date |
|                     |                 |                              |                        | TM 5-6675-200-14 Operator, Organizational, Direct Support, and General Support Maintenance Manual |                 |                       | 1               |                 |      |      |      |
| 2-7                 | 4               | 6675-00-353-4103             | 3A55 (89905)           | Pin, adjusting  |                 |                       | 2               |                 |      |      |      |
| 2-7                 | 6               | 5120-00-429-2948             | HDW1-5 (89905)         | Screwdriver, jewelers   |                 |                       | 1               |                 |      |      |      |
| 2-7                 | 8               | 5120-00-446-2860             | HDW1-10 (89905)        | Screwdriver, large  |                 |                       | 1               |                 |      |      |      |
| 2-7                 | 3               | 8330-00-965-1722             | KKC300 (89905)         | Chamois   |                 |                       | 1               |                 |      |      |      |
| 2-7                 | 5               | 7920-00-011-8517             | 109335 (89905)         | Brush, dust   |                 |                       | 1               |                 |      |      |      |
| 2-10                | 4               | 6420-00-859-5936             | HEG3-64 (89905)        | Lamps   |                 |                       | 4               |                 |      |      |      |
| 2-7                 | 14              | 6675-00-446-1762             | HDF3-4 (89905)         | Container, lubricant  |                 |                       | 1               |                 |      |      |      |

Page C-1. Appendix C is superseded as follows:

**APPENDIX C  
ADDITIONAL AUTHORIZATION LIST**

Section I. INTRODUCTION

**C-1. Scope**

This appendix lists additional items you are authorized for the support of the theodolite.

**C-2. General**

This list identifies items that do not have to accompany the theodolite and that do not have to be turned in with

it. These items are authorized to you by CTA, MTOE, TDA or JTA.

**C-3. Explanation of Listing**

National stock number, descriptions, and quantities are provided to help you identify and request the additional items you require to support this equipment.

Section II. ADDITIONAL AUTHORIZATION LIST

| (1)<br>National<br>stock<br>number | (2)<br>Description |                        | (3) | (4)         |
|------------------------------------|--------------------|------------------------|-----|-------------|
|                                    | Part number & FSCM | Usable on codes        | U/M | Qty<br>auth |
| 6135-00-120-1020                   | BA30 (81349)       | Battery Dry, 1.5 Volts | ea  | 8           |

Appendix D is added after Appendix C as follows:

**APPENDIX D  
MAINTENANCE ALLOCATION CHART**

Section I. INTRODUCTION

**D-1. General**

*a.* This section provides a general explanation of all maintenance and repair functions authorized at various maintenance levels.

*b.* Section II designates overall responsibility for the performance of maintenance functions on the identified end item or component and the work measurement time required to perform the functions by the designated maintenance level. The implementation of the maintenance functions upon the end item or component will be consistent with the assigned maintenance functions.

*c.* Section III lists the special tools and test equipment required for each maintenance function as referenced from section II.

*d.* Section IV contains supplemental instructions or explanatory notes for a particular maintenance function.

**D-2. Explanation of Columns in Section II**

*a. Column (1), Group Number.* A number is assigned to each group in a top down breakdown sequence. The applicable groups are listed on the MAC in disassembly sequence beginning with the first group removed.

*b. Column (2), Functional Group.* This column contains a brief description of the components of each numerical group.

*c. Column (3), Maintenance Functions.* This column lists the various maintenance functions (A through K). The lowest maintenance level authorized to perform these functions is indicated by a symbol in the appropriate column. Work measurement time standards (the active repair time required to perform the maintenance function) are shown directly below the symbol identifying the maintenance level. The symbol designations for the various maintenance levels are as follows:

- C . . . . . Operator or crew
- O . . . . . Organization maintenance
- F . . . . . Direct support maintenance
- H . . . . . General support maintenance
- D . . . . . Depot maintenance

The maintenance functions are defined as follows:

*A—Inspect:* To determine serviceability of an item by comparing its physical, mechanical, and electrical characteristics with established standards through examination.

B— *Test*: To verify serviceability and detect incipient failure by measuring the mechanical or electrical characteristics of an item and comparing those characteristics with prescribed standards.

C— *Service*: Operations required periodically to keep an item in proper operating condition, i.e., to clean, to preserve, to drain, to paint, or to replenish fuel, lubricants, hydraulic fluids, or compressed air supplies,

D— *Adjust*: To maintain within prescribed limits, by bringing into proper or exact position, or by setting the operating characteristics to specified parameters.

E— *Aline*: To adjust specified variable elements of an item to bring about optimum or desired performance.

F— *Calibrate*: To determine and cause corrections to be made or to be adjusted on instruments or test measuring and diagnostic equipments used in precision measurement. Consists of comparisons of two instruments, one of which is a certified standard of known accuracy, to detect and adjust any discrepancy in the accuracy of the instrument being compared.

G— *Install*: The act of emplacing, seating, or fixing into position an item, part, or module (component or assembly) in a manner to allow the proper functioning of an equipment or system.

H— *Replace*: The act of substituting a serviceable like type part, subassembly, or module (component or assembly) for an unserviceable counterpart.

I— *Repair*: The application of maintenance services (inspect, test, service, adjust, aline, calibrate, or replace) or other maintenance actions (welding, grinding, riveting, straightening, facing, remachining or resurfacing) to restore serviceability to an item by correcting specific damage, fault, malfunction, or failure in a part, subassembly, module (component or assembly), end item, or system.

J— *Overhaul*: That maintenance effort (service/action) necessary to restore an item to a completely serviceable/operational condition as prescribed by maintenance standards (i.e., DMWR) in appropriate technical publication. Overhaul is normally the highest degree of maintenance performed by the Army. Overhaul does not normally return an item to like new con-

dition.

K— *Rebuild*: Consists of those services/actions necessary for the restoration of unserviceable equipment of a like new condition in accordance with original manufacturing standards. Rebuild is the highest degree of materiel maintenance applied to Army equipment. The rebuild operation includes the act of returning to zero those age measurement (hours/miles, etc.) considered in classifying Army equipment/components.

d. *Column (4), Tools and Equipment*. This column is provided for referencing by code the special tools and test equipment, (sec III) required to perform the maintenance functions (sec II).

e. *Column (5), Remarks*. This column is provided for referencing by code the remarks (see IV) pertinent to the maintenance functions.

#### D-3. Explanation of Columns in Section III

a. *Reference Code*. This column consists of a number and a letter separated by a dash entered from column 4 on the MAC. The number references the special tools and test equipment requirements and the letter represents the specific maintenance function the item is to be used with. The letter is representative of columns A through K on the MAC.

b. *Maintenance Category*. This column shows the lowest level of maintenance authorized to use the special tools or test equipment.

c. *Nomenclature*. This column lists the name or identification of the tools or test equipment.

d. *Tool Number*. This column lists the manufacturer's code and part number, or National stock number of tools and test equipment.

#### D4. Explanation of Columns in Section IV

a. *Reference Code*. This column consists of two letters separated by a dash, entered from column (5), section II. The first letter references the remark and the second letter references a maintenance function, column (3), A through to which the remark applies.

b. *Remarks*. This column lists information pertinent to the maintenance function being performed, as indicated on the MAC Section II.



| (1)<br>Group No. | (2)<br>Functional group   | (3)<br>Maintenance functions |      |          |          |       |           |          |          |          |          |         | (4)<br>Tools and equipment | (5)<br>Remarks |
|------------------|---|------------------------------|------|----------|----------|-------|-----------|----------|----------|----------|----------|---------|----------------------------|----------------|
|                  |   | A                            | B    | C        | D        | E     | F         | G        | H        | I        | J        | K       |                            |                |
|                  |   | Inspect                      | Test | Service  | Adjust   | Align | Calibrate | Install  | Replace  | Repair   | Overhaul | Rebuild |                            |                |
| 0509             | 05 --- Continued<br>Eyepiece Assembly.....                          | ...                          | ...  | O<br>0.1 | ...      | ...   | ...       | ...      | ...      | D<br>0.6 | ...      | ...     | .....                      | K-C            |
| 0510             | Reflector, Bearing,<br>Mounts                                       | D<br>0.1                     | ...  | ...      | ...      | ...   | ...       | ...      | D<br>2.0 | ...      | ...      | ...     | .....                      |                |
| 0511             | Housing, sights .....   | ...                          | ...  | ...      | D<br>1.0 | ...   | ...       | ...      | D<br>4.0 | ...      | ...      | ...     | .....                      |                |
| 0512             | Box Assembly, Battery .....   | ...                          | ...  | ...      | ...      | ...   | ...       | ...      | O<br>0.1 | F<br>2.0 | ...      | ...     | .....                      |                |
| 0513             | Light, Hand .....   | O<br>0.1                     | ...  | ...      | ...      | ...   | ...       | O        | F<br>0.2 | 0.3      | ...      | ...     | .....                      |                |
| 0514             | Circuits, Components.....   | O                            | ...  | ...      | ...      | ...   | ...       | ...      | F<br>0.5 | ...      | ...      | ...     | .....                      | L-A            |
| 0515             | Mounted Connecting<br>Devices                                       | O<br>0.1                     | ...  | ...      | ...      | ...   | ...       | ...      | D<br>1.0 | ...      | ...      | ...     | .....                      |                |
| 0601             | 06 Miscellaneous Wiring and Fittings<br>Cord Assembly,<br>Extension | O<br>0.1                     | ...  | ...      | ...      | ...   | ...       | ...      | O<br>0.1 | ...      | ...      | ...     | .....                      |                |
| 0602             | Illumination Assembly .....   | O<br>0.1                     | ...  | ...      | ...      | ...   | ...       | ...      | O<br>0.2 | F<br>0.2 | ...      | ...     | .....                      |                |
| 0603             | Wire, Hook-up, Internal .....                                       | D<br>1.0                     | ...  | ...      | ...      | ...   | ...       | ...      | D<br>1.5 | ...      | ...      | ...     | .....                      |                |
| 0604             | Plug Assembly, Battery<br>Box                                       | O<br>0.1                     | ...  | ...      | ...      | ...   | ...       | ...      | F<br>0.3 | ...      | ...      | ...     | .....                      |                |
| 0701             | 07 Compass & Level<br>Compass Assembly.....                         | ...                          | ...  | O<br>1.0 | ...      | ...   | ...       | O<br>0.1 | H<br>3.0 | ...      | ...      | ...     | .....                      | M-C            |
| 0702             | Level Assemblies, Circular<br>and Altitude                          | ...                          | ...  | D<br>0.1 | O<br>0.1 | ...   | ...       | ...      | F<br>0.2 | D<br>1.5 | ...      | ...     | 2-D, 3-D                   |                |
| 0703             | Vial Assembly, Telescope<br>Level                                   | ...                          | ...  | O<br>1.5 | O<br>1.5 | ...   | ...       | ...      | F<br>1.5 | D<br>1.5 | ...      | ...     | .....                      |                |
| 0704             | Retainers: Housing,<br>springs                                      | O<br>0.5                     | ...  | ...      | ...      | ...   | ...       | ...      | D<br>3.5 | ...      | ...      | ...     | .....                      |                |
|                  | 08 Tripods.....   | ...                          | ...  | O<br>0.1 | O        | ...   | ...       | ...      | O<br>0.1 | O<br>2.0 | ...      | ...     | ... 4-I                    |                |

**Section III. SPECIAL TOOL AND SPECIAL TEST EQUIPMENT REQUIREMENTS**

| Reference code | Maintenance category | Nomenclature   | Tool number      |
|----------------|----------------------|----------------|------------------|
| 1 - D          | 0                    | Pin, adjusting | 6675-00-353-4103 |
| 2 - D          | 0                    | Screwdriver    | 5120-00-429-2940 |
| 3 - D          | 0                    | Screwdriver    | 5120-00-446-2860 |
| 4 - I          | 0                    | Wrench, tripod | 5120-00-378-9520 |

**Section IV. REMARKS**

| Reference code | Remarks  |
|----------------|----------|
| A-C            | External |
| B-D            | External |
| C-A            | External |
| D-C            | External |
| E-D            | External |
| F-C            | External |
| G-C            | External |
| H-C            | External |
| I-C            | External |
| J-C            | External |
| K-C            | Clean    |
| L-A            | External |
| M-C            | External |

Appendix E is added after Appendix D as follows:

**APPENDIX E**  
**EXPENDABLE SUPPLIES AND MATERIALS LIST**

Section I. INTRODUCTION

**E-1. Scope**

This appendix lists expendable supplies and materials you will need to operate and maintain the theodolite. These items are authorized to you by CTA50-970, Expendable Items (except Medical, Class V, Repair Parts, and Heraldic Items).

**E-2. Explanation of Columns**

*a. Column 1 — Item number.* This number is assigned to the entry in the listing and is referenced in the narrative instructions to identify the material (e.g., "Use cleaning compound, Item 5, App.>").

*b. Column 2 — Level.* This column identifies the lowest level of maintenance that requires the listed item.

- C- Operator/Crew
- O- Organizational maintenance
- F- Direct support maintenance
- H- General support maintenance

*c. Column 3 — National Stock Number.* This is the National stock number assigned to the item; use it to request or requisition the item.

*d. Column 4 — Description.* Indicates the Federal item name and, if required, a description to identify the item. The last line for each item indicates the part number followed by the Federal Supply Code for Manufacturer (FSCM) in parenthesis, if applicable.

*e. Column 5 — Unit of Measure (U/M).* Indicates the measure used in performing the actual maintenance function. This measure is expressed by a two-character alphabetical abbreviation (e.g., ea, in, pr). If the unit of measure differs from the unit of issue, requisition the lowest unit of issue that will satisfy your requirements.

Section II. EXPENDABLE SUPPLIES AND MATERIALS LIST

| (1)<br>Item<br>number | (2)<br>Level | (3)<br>National<br>stock<br>number | (4)<br>Description  | (5)<br>U/M |
|-----------------------|--------------|------------------------------------|---|------------|
| 1                     | C            | 6850-00-680-2233                   | Desiccant Activated 1.5 lb.   | lb         |
| 2                     | C            | 7920-00-401-8034                   | Cloth, lint-free, nonabrasive, general purpose, part No. 1001                 | bx         |
| 3                     | C            | 9150-00-985-7244                   | Grease, instrument, and aircraft (GIA) MIL-G-23827, 4 oz.                     | tu         |
| 4                     | C            | 9150-00-252-6382                   | Oil, clock and watch (OCW) MIL-L-3918   | bt         |
| 5                     | C            | 6810-00-223-2739                   | Acetone, technical, 1 pt. can; Fed. Spec. MMM-A-185                           | pt         |
| 6                     | C            | 6850-00-664-5685                   | Cleaning Solvent Fed. Spec. P-D-680   | qt         |
| 7                     | C            | 6640-00-597-6745                   | Lens tissue, NNNP40TYPEICL2 (81348) 4 X 6 heavyweight ,<br>50 sheets per book | bk         |
| 8                     | C            | 5120-01-018-5908                   | Orange sticks 13218E3036 (97403)  | pk         |

TM 5-6675-200-14

By Order of the Secretary of the Army:

**BERNARD W. ROGERS**  
*General, United States Army*  
*Chief of Staff*

Official:

**J. C. PENNINGTON**  
*Brigadier General, United States Army*  
*The Adjutant General*

Distribution:

To be distributed in accordance with DA Form 12-25A, Operator maintenance requirements for Surveying Equipment.



T E C H N I C A L M A N U A L }  
 N O . 5 - 6 6 7 5 - 2 0 0 - 1 4 }

H E A D Q U A R T E R S ,  
 D E P A R T M E N T O F T H E A R M Y  
 W A S H I G T O N , D . C . , 3 1 M a y 1 9 7 3

OPERATOR, ORGANIZATIONAL, DIRECT SUPPORT  
 AND GENERAL SUPPORT MAINTENANCE MANUAL

THEODOLITE: DIRECTIONAL;

5.9 IN. LG TELESCOPE; DETACHABLE TRIBRACH,

W/ACCESSORIES AND TRIPOD

(WILD HEERBRUGG MODEL T-16-0.2 MIL)

( FSN 6675-542-1683)

|          | Paragraph  | Page      |
|----------|--|-----------|
| CHAPTER  | 1. INTRODUCTION  |           |
| Section  | I. General . . . . .   | 1-1 1-1   |
|          | II. Description and data . . . . .                                     | 1-7 1-1   |
| CHAPTER  | 2. OPERATING INSTRUCTIONS  |           |
| Section  | I. Operating procedures . . . . .                                      | 2-1 2-1   |
|          | II. Operation of Auxiliary Equipment . . . . .                         | 2-28 2-11 |
|          | III. Operation Under Unusual Conditions . . . . .                      | 2-31 2-14 |
| CHAPTER  | 3. ORGANIZATIONAL MAINTENANCE  |           |
| Section  | I. Service Upon Receipt of Material. . . . .                           | 3-1 3-1   |
|          | II. Repair Parts, Special Tools and Equipment. . . . .                 | 3-5 3-5   |
|          | III. Lubrication Instructions . . . . .                                | 3-8 3-6   |
|          | IV. Preventive Maintenance Checks and Services. . . . .                | 3-10 3-6  |
|          | V. Troubleshooting . . . . .   | 3-12 3-8  |
|          | VI. Carrying Cases . . . . .   | 3-14 3-9  |
|          | VII. Eyepieces . . . . .   | 3-17 3-12 |
|          | VIII. Tribrach, Foot Screw, and Star Plate Assemblies . . . . .        | 3-21 3-13 |
|          | IX. Mirror Assemblies . . . . .  | 3-23 3-13 |
|          | X. Tripod and Tripod Accessory Case . . . . .                          | 3-26 3-14 |
|          | XI. Plumb Bob and Tripod Wrench . . . . .                              | 3-29 3-16 |
|          | XII. Compass Assembly . . . . .  | 3-31 3-17 |
|          | XIII. Circular and Plate Levels . . . . .                              | 3-33 3-18 |
|          | XIV. Alidade and Optical Plumb Assembly . . . . .                      | 3-35 3-18 |
|          | XV. Hand Lamp, Plug-in Lamp, and Battery Box Assemblies . . . . .      | 3-38 3-19 |
|          | XVI. Accessory Case and Accessories . . . . .                          | 3-42 3-19 |
| CHAPTER  | 4. DIRECT SUPPORT AND GENERAL SUPPORT MAINTENANCE INSTRUCTIONS         |           |
| Section  | I. Repair Parts, Special Tools and Equipment . . . . .                 | 4-1 4-1   |
|          | II. Troubleshooting . . . . .  | 4-3 4-1   |
|          | III. General Maintenance . . . . .                                     | 4-5 4-2   |
|          | IV. Illumination System . . . . .                                      | 4-9 4-6   |
| APPENDIX | A. REFERENCES . . . . .  | A-1       |
|          | B. BASIC ISSUE ITEMS LIST AND ITEMS TROOP INSTALLED OR AUTHORIZED LIST | B-1       |
|          | C. MAINTENANCE ALLOCATION CHART. . . . .                               | C-1       |
| INDEX    |  | I-1       |

\* This manual supersedes TM 5-6675-200-15, 4 May 1960, including all changes.

# LIST OF ILLUSTRATIONS

| N u m b e r | T i t l e   | P a g e |
|-------------|---|---------|
| 1 - 1       | Theodolite, front view. . . . .   | 1-2     |
| 1 - 2       | Theodolite, left side view. . . . .   | 1-4     |
| 1 - 3       | Theodolite, right side view. . . . .  | 1-5     |
| 1 - 4       | Theodolite, rear view. . . . .  | 1-6     |
| 2 - 1       | Illumination system and compass assembly, installed view. . . . .   | 2-2     |
| 2 - 2       | Vertical (upper) and horizontal (lower) circle scales. . . . .  | 2-4     |
| 2 - 3       | Theodolite removed from base assembly. . . . .  | 2-5     |
| 2 - 4       | Tripod and plumb bob centered on station point. . . . .   | 2-6     |
| 2 - 5       | Tripod accessory case and accessories, unpacked view. . . . .   | 2-7     |
| 2 - 6       | Theodolite in carrying case. . . . .  | 2-7     |
| 2 - 7       | Accessory case and accessories, unpacked view. . . . .  | 2-9     |
| 2 - 8       | Leveling the theodolite with the foot screws . . . . .  | 2-10    |
| 2 - 9       | Diagonal eyepiece prism and telescope sunglasses, installed view. . . . .   | 2-12    |
| 2 - 10      | Battery box and accessories, unpacked view . . . . .  | 2-13    |
| 3 - 1       | Theodolite in shipping case. . . . .  | 3-1     |
| 3 - 2       | Theodolite with metal hood assembly removed . . . . .   | 3-2     |
| 3 - 3       | Tripod assembly, unpacked view. . . . .   | 3-3     |
| 3 - 4       | Field pack, unpacked view . . . . .   | 3-4     |
| 3 - 5       | Metal hood and base assemblies, exploded view. . . . .  | 3-10    |
| 3 - 6       | Desiccant container, exploded view . . . . .  | 3-12    |
| 3 - 7       | Tripod assembly, exploded view . . . . .  | 3-14    |
| 3 - 8       | Plumb bob and tripod wrench, exploded view. . . . .   | 3-17    |
| 3 - 9       | Compass needle screw, removal points . . . . .  | 3-18    |
| 4 - 1       | Vertical collimation level, vertical collimation lever and<br>illumination lens assemblies, removal points . . . . .    | 4-2     |
| 4 - 2       | Collimation level assembly, exploded view. . . . .  | 4-3     |
| 4 - 3       | Collimation level mirror and lever cover, illumination mirror,<br>and reticle mirror assemblies, exploded view. . . . . | 4-5     |
| 4 - 4       | Battery box, exploded view . . . . .  | 4-7     |
| 4 - 5       | Hand lamp and cable assembly, exploded view . . . . .   | 4-9     |
| 4 - 6       | Electrical illumination assembly, exploded view. . . . .  | 4-11    |

## Section I. GENERAL

**1-1. Scope**

This manual is for your use in operating and maintaining the Wild Heerbrugg model T-16 theodolite.

**1-2. Maintenance Forms and Records**

Maintenance forms and records that you are required to use are explained in TM 38-750.

**1-3. Reporting of Errors**

You can improve this manual by calling attention to errors and by recommending improvements using DA Form 2028 (Recommended Changes to Publications), or by a letter, and mail directly to the

Commanding General, U. S. Army Troop Support. Command, ATTN: AMSTS-MPP, 4300 Goodfellow Boulevard, St. Louis, Missouri 63120.

**1-4. Equipment Serviceability Criteria**

This equipment is not covered by an ESC.

**1-5. Destruction of Army Materiel to Prevent Enemy Use**

Refer to TM 750-244-3.

**1-6. Administrative Storage**

Refer to TM 740-90-1, Administrative Storage.

## Section II. DESCRIPTION AND DATA

**1-7. Description**

The Wild Heerbrugg model T-16 theodolite (figs. 1-1 through 1-4) is a precision, directional-type surveying and tracking instrument. It has both vertical and horizontal circle scales, calibrated in mils, for reading and value of angles. The instrument has a telescope, microscope, clamps and slow motion screws, and leveling vials and foot screws for leveling. A circular compass, diagonal and sunglass eyepieces, extension leg tripod

illumination system, and accessory case with accessories are provided with the theodolite. The maintenance paragraphs of this manual contain detailed descriptions of the components of the theodolite.

**1-8. Differences in Models**

This manual covers only the Wild Heerbrugg model T-16-0.2 MIL theodolite. No known differences exist for the model covered by this manual.

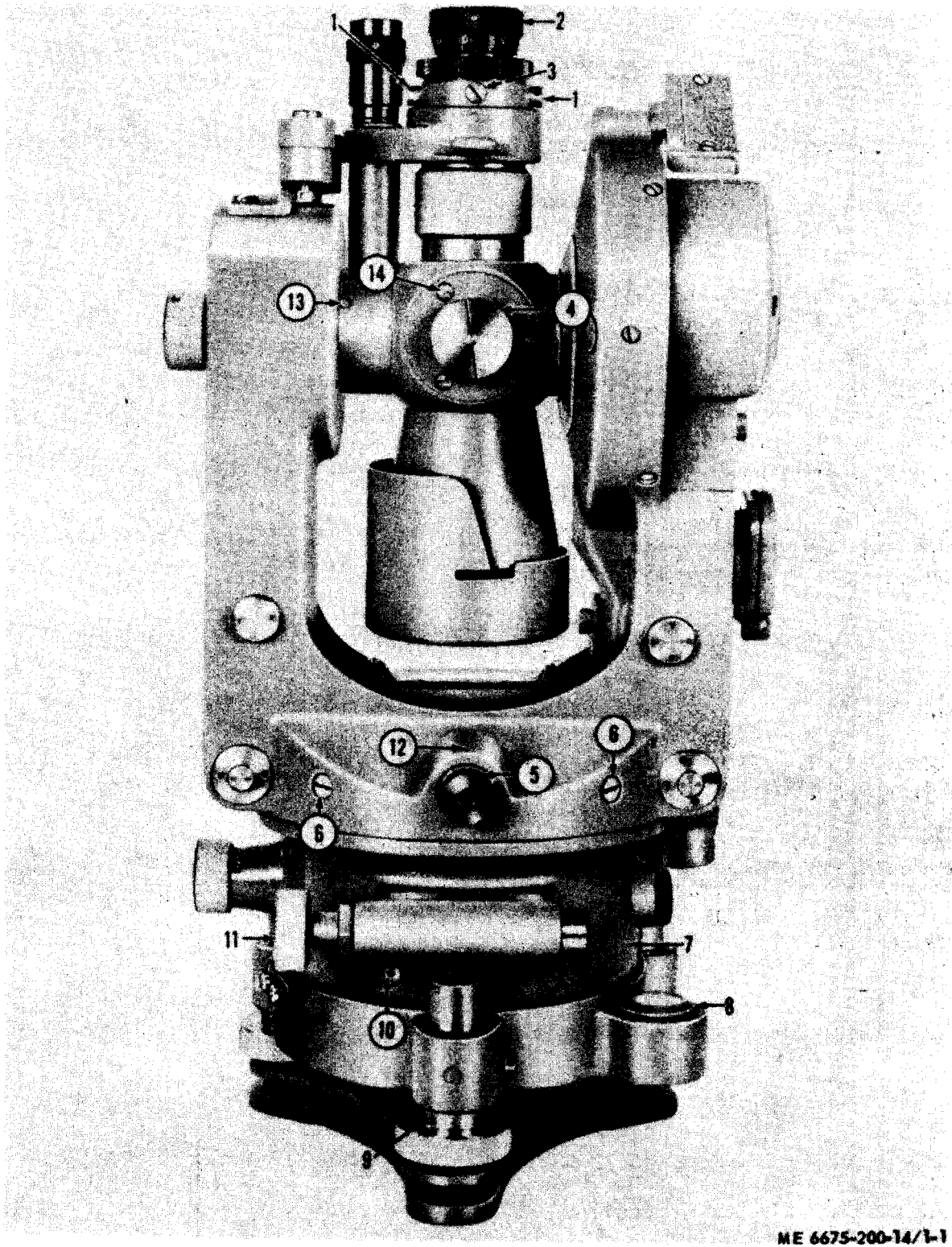
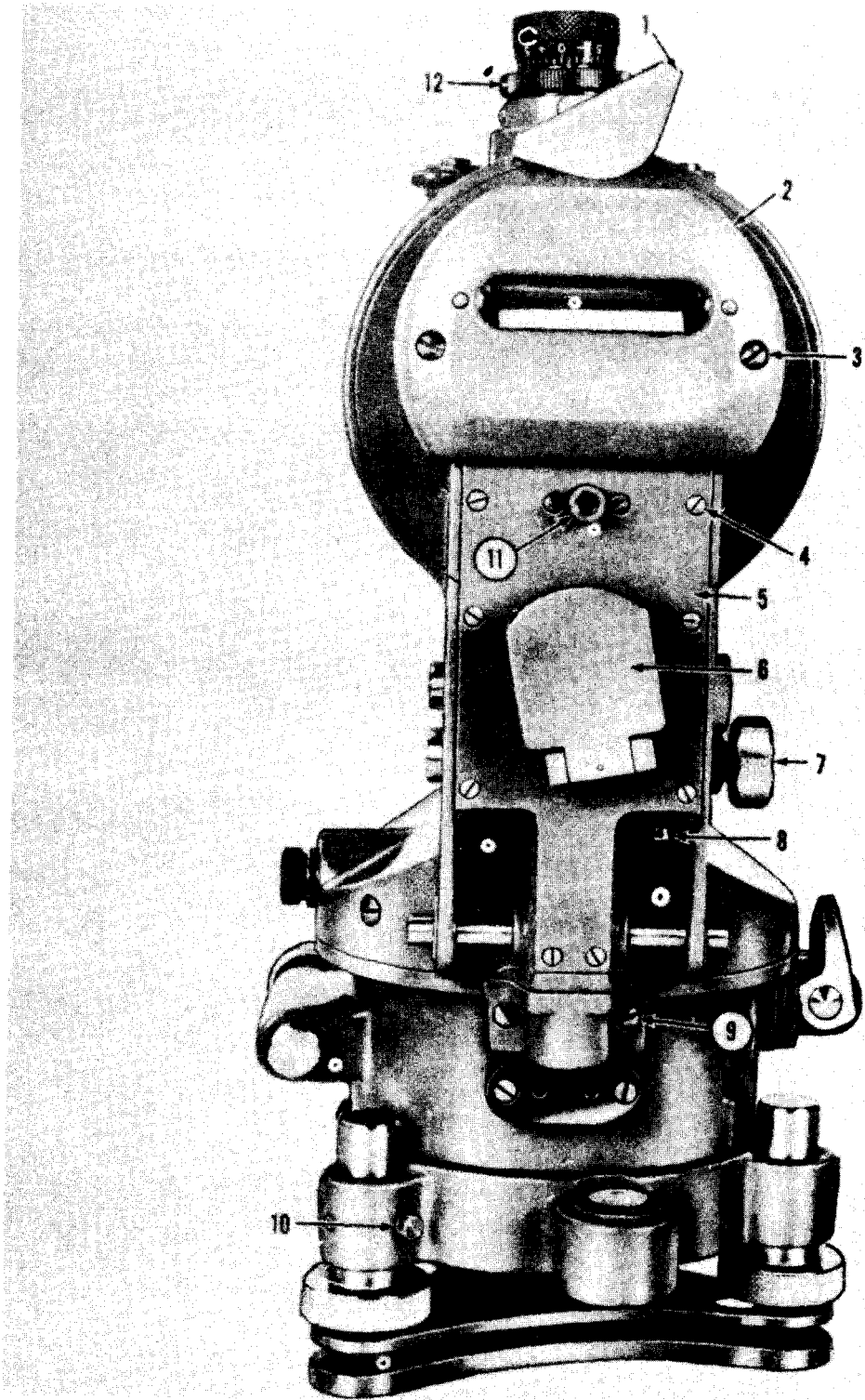

Figure 1-1. Theodolite, front view.

Key to figure 1-1:

1. Screw, adjusting (spec) (2 rqr)
2. Setscrew
3. Holding screw (spec) (2 rqr)
4. Reticle mirror knob
5. Optical plumb eyepiece
6. Cover screw (spec) (2 rqr)
7. Horizontal circle housing

8. Circular level
9. Foot screw
10. Adjusting screw (spec)
11. Horizontal slow motion screw
12. Setscrew
13. Setscrew (3 rqr)
14. Screw, machine, (spec) (3 rqr)



ME 6675-200-14/1-2

- |                                      |  |
|--------------------------------------|--|
| 1. Collimation level mirror assembly | 7. Collimation slow motion screw                 |
| 2. Collimation level cover           | 8. Collimation slow motion screw adjusting screw |
| 3. Screw, machine (spec) (2 rqr)     | 9. Screw, machine (spec) (2 rqr)                 |
| 4. Screw, left side cover (8 rqr)    | 10. Foot screw adjusting screw                   |
| 5. Left side support cover           | 11. Plug-in lamp mounting nut                    |
| 6. Illumination mirror assembly      | 12. Telescope eyepiece focusing ring             |

Figure 1-2. Theodolite, left side view.

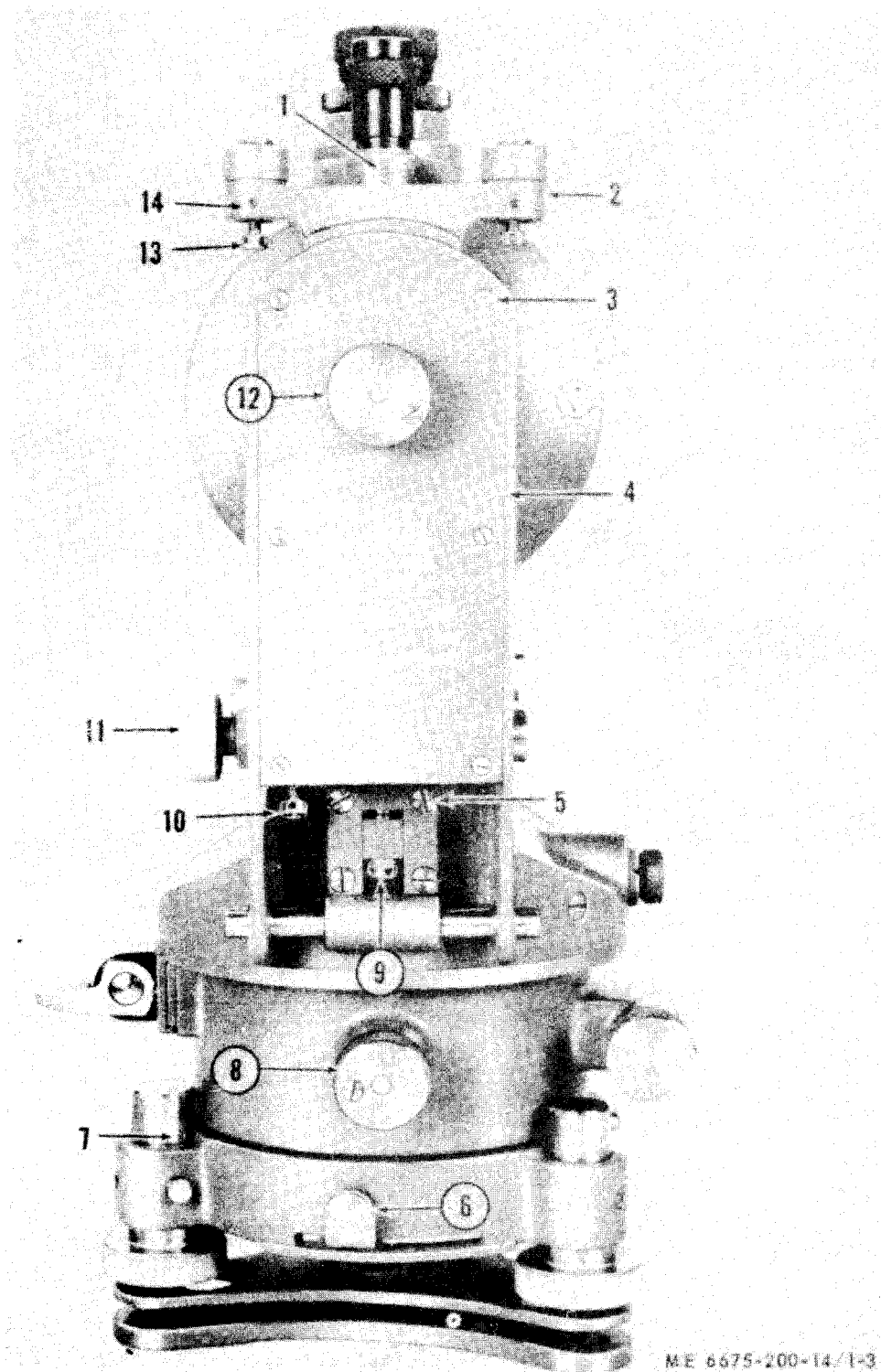

- |  |  |
|--|--|
| 1. Screw, lock                         | 8. Horizontal clamp screw                |
| 2. Compass holder                      | 9. Plate level adjusting screw           |
| 3. Screw, right side cover (6 rqr)     | 10. Vertical slow motion adjusting screw |
| 4. Right side support cover            | 11. Vertical slow motion screw           |
| 5. Screw, plate level mounting (4 rqr) | 12. Vertical clamp screw                 |
| 6. Tribach clamp lever                 | 13. Compass adjusting screw (2 rqr)      |
| 7. Setscrew (3 rqr)                    | 14. Setscrew (2 rqr)                     |

Figure 1-3. Theodolite, right side view.

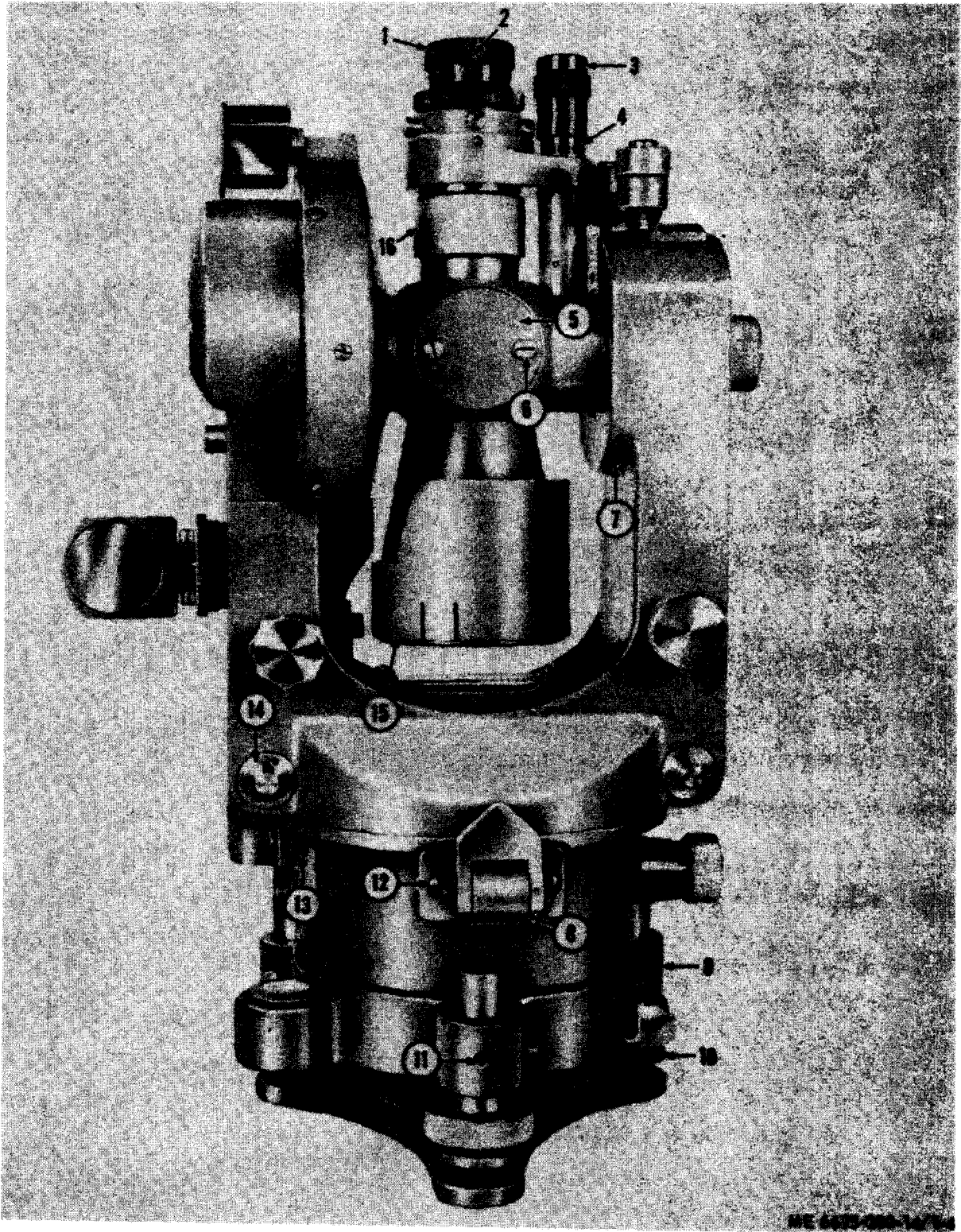

Figure 1.4. Theodolite, rear view.





## CHAPTER 2

### OPERATING INSTRUCTIONS

---

#### WARNING

If equipment fails to operate, refer to troubleshooting procedures in Chapter 3.

#### Section 1. OPERATING PROCEDURES

##### 2-1. General

This section describes, locates, illustrates, and furnishes the operator sufficient information pertaining to the various controls, scales, and levels provided for the proper operation of the theodolite. This section also provides instructions on handling and setting up the theodolite, the basic motions and adjustments, and tells how to coordinate the basic motions and adjustments to perform the specific tasks for which the theodolite is designed.

##### 2-2. Vertical Clamp Screw

The vertical clamp screw ( 12, fig. 1-3) is located on the right side cover of the theodolite. The clamp is pressure-actuated by the clamp screw and allows the telescope to be turned 360° on its axis, or to be locked in a fixed position.

#### CAUTION

**Use only the slightest pressure on the knurled knob to release or tighten the vertical clamp.**

##### 2-3. Reticle Mirror Knobs

The reticle mirror knob (4, fig. 1-1 ) is located on the top of the telescope axle. This knob controls the amount of light which can fall on the telescope reticle.

##### 2-4. Telescope Focusing Ring

The telescope focusing ring (16, fig. 1-4) is a knurled control located adjacent to the eyepiece end of the telescope. This ring is used to bring the object to be sighted into focus.

##### 2-5. Telescope Eyepiece

The telescope eyepiece (1, fig. 1-4) is a knurled and graduated assembly located on the eyepiece end of the telescope. It is used to bring the telescope reticle into focus.

The microscope assembly (4, fig. 1-4) is an assembly located on the telescope axis and is used to bring the horizontal and vertical circle images into focus.

##### 2-7. Compass Holder

The compass holder (2, fig. 1-3) is located on the upper right side of the alidade and is used to secure the circular compass to the theodolite. Two adjusting screws in the base of the tubes of the holder are used by the operator to level the compass.

##### 2-8. Compass Caging Knob

The compass caging knob (19, fig. 2-1) is located on the bottom of the compass, and is used by the operator to release the compass circle, allowing the circle to swing freely on the needle screw. When the knob is released, the circle is withdrawn from the pivot by a spring.

##### 2-9. Compass Clamp Screw

The compass clamp screw (1, fig. 2-1 ) is located on the rear side of the compass housing, and is used by the operator to lock the housing in any desired position on the compass base.

##### 2-10. Compass Eyepiece

The compass eyepiece (3, fig. 2-1 ), located on the front side of the compass housing, is used by the operator to focus the reference mark assembly and to read the compass azimuth scale.

##### 2-11. Compass Index Ring

The compass index or declination graduation ring (4, fig. 2-1) is located on the lower portion of the compass housing, and is used by the operator for azimuth reference and orientation.

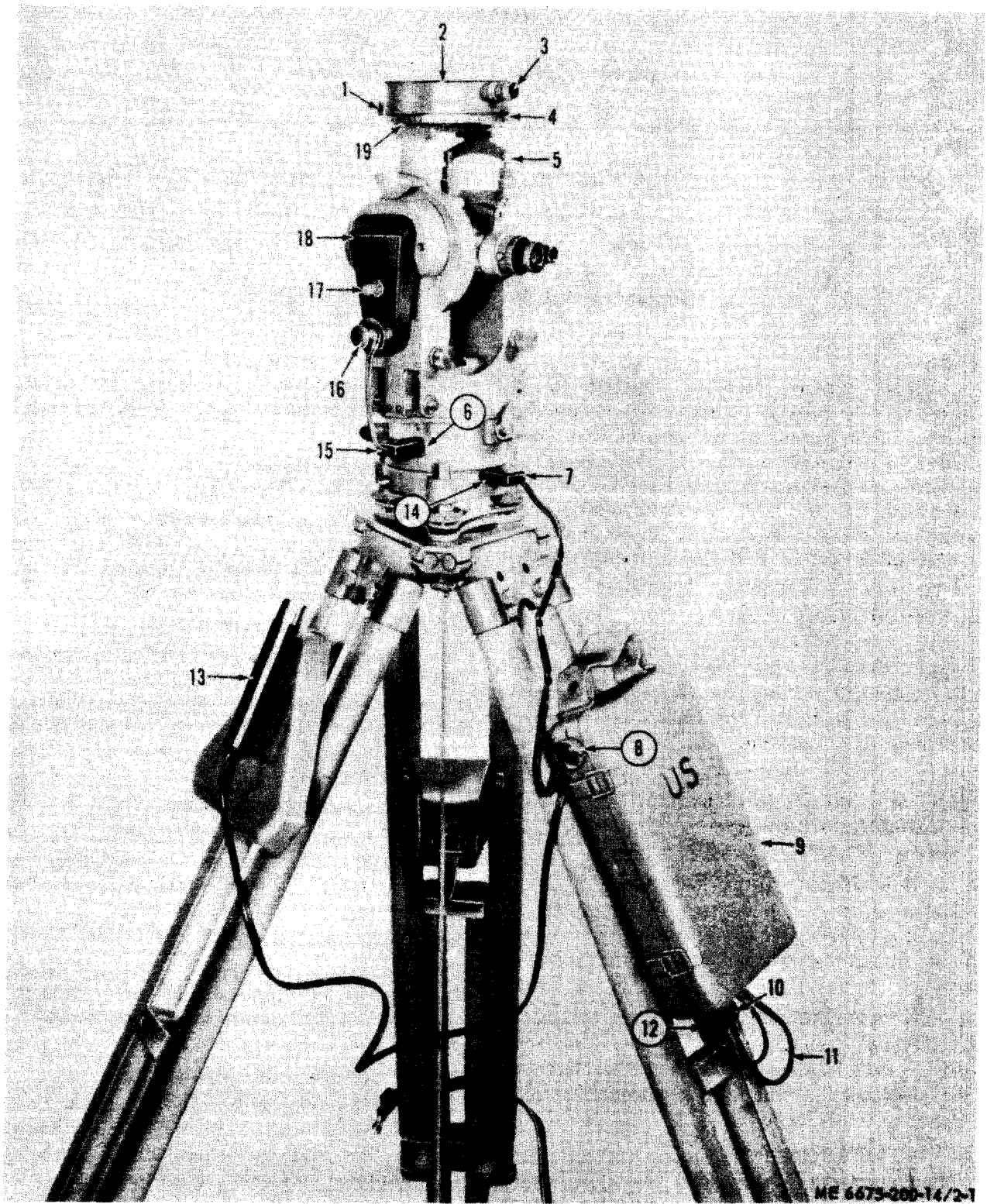

Figure 2-1. Illumination system and compass assembly, installed view.

Key to figure 2-1:

1. Compass **clar** screw
2. Compass assembly
3. Compass eyepiece
4. Index (declination graduation) ring
5. Compass bolder with bolts
6. Alidade connector receptacle
7. Battery cable connector plug
8. Switch and rheostat knob
9. Battery box
10. Hand lamp cable connector plug
11. T r i p o d
12. Battery cable connector plug
13. Hand lamp
14. Inner base housing receptacle
15. Plug-in lamp connector plug
16. Plug-in lamp
17. Mounting screw
18. Plug-in lamp reflector
19. Compass caging knob

#### **2-12. Vertical Slow Motion Screw**

The vertical slow motion screw (11, fig. 1-3) is located on the rear of the right alidade standard. This knurled screw provides precision adjustment in the final vertical positioning of the telescope.

#### **2-13. Horizontal Slow Motion Screw**

The horizontal slow motion screw (11, fig. 1-1) is located on the front of the horizontal circle housing (7). This knurled screw provides precision adjustment in the horizontal positioning of the telescope.

#### **2-14. Horizontal Circle Clamp**

The horizontal circle clamp (8, fig. 1-4) is located on the rear of the theodolite in the upper part of the horizontal circle housing (7, fig. 1-1). This clamp is used by the operator to lock the horizontal circle in any given position during orientation.

#### **2-15. Collimation Slow Motion Screw**

The collimation slow motion screw (7, fig. 1-2) is

located on the rear of the left alidade standard. This knurled screw provides adjustment for a true reading of the vertical circle if the vertical circle level is not at coincidence, as would be indicated by a vertical circle reading above or below 1,600 mils after horizontal (lateral) collimation.

#### **2-16. Horizontal Clamp Screw**

The horizontal clamp screw (8, fig. 1-3) is located on the right side of the horizontal circle housing (7, fig. 1-1). This control locks the upper part of the theodolite in any desired position on its horizontal plane.

#### **2-17. Foot Screws**

The three foot screws (9, fig. 1-1) are located on the tribrach assembly, (9, fig. 1-4). These foot screws are used in conjunction with the circular and plate levels to quickly and accurately true up the theodolite.

#### **2-18. Tribrach Clamp Lever**

The tribrach clamp lever (6, fig. 1-3) is located on the tribrach assembly (9, fig. 1-4), and secures the theodolite to the tribrach assembly.

#### **2-19. Optical Plumb**

The optical plumb eyepiece (5, fig. 1-1) is located in the base of the alidade. The eyepiece is used by the operator to quickly determine whether the theodolite is centered exactly over the station point.

#### **2-20. Vertical Circle Scale**

The vertical circle scale (fig. 2-2) appears in the upper part of the window as viewed through the microscope eyepiece. The scale is graduated in tenths of mils (6,400 mils equal 360°), with each mil being numbered.

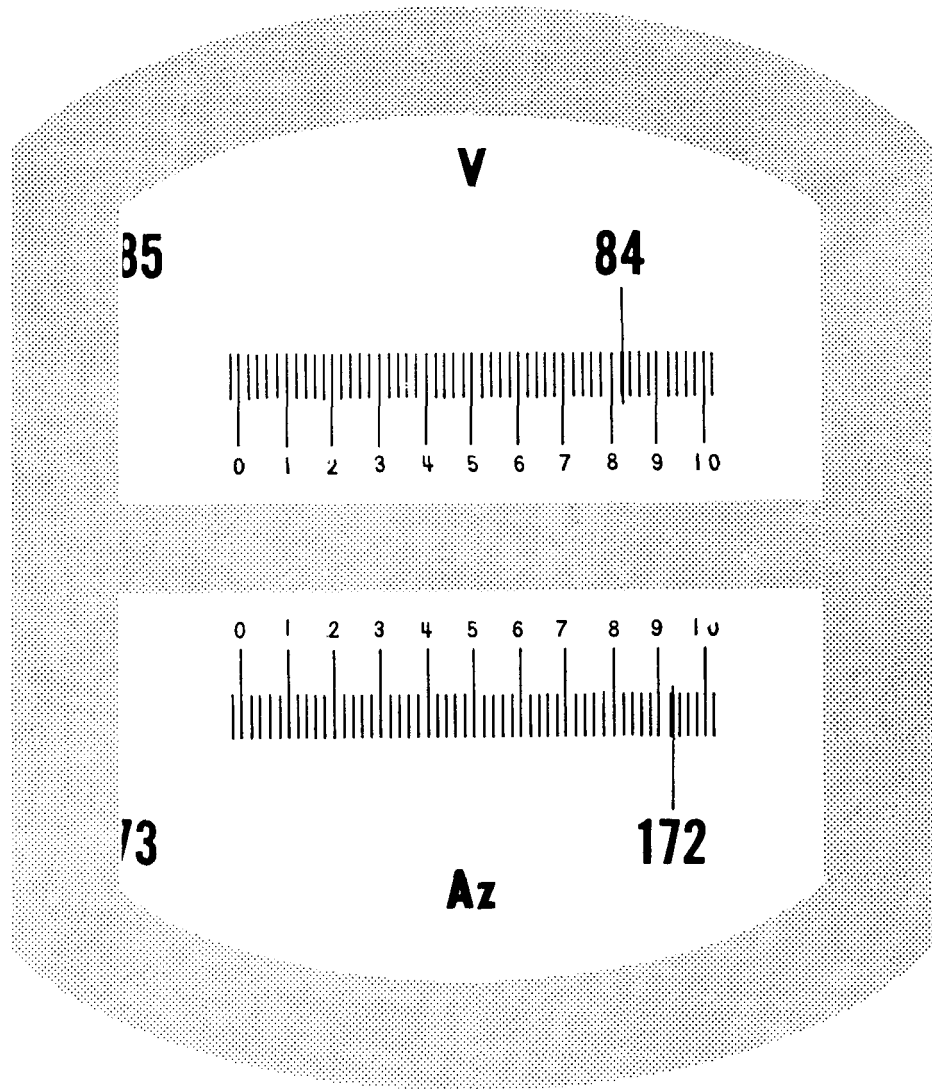

ME 6675-200-14/2-2

Figure 2-2. Vertical (upper) and horizontal (lower) circle scales.

**2-21. Horizontal Circle Scale**

The horizontal circle scale (fig. 2-2) appears in the lower part of the window as viewed through the microscope eyepiece. This scale is graduated the same as the vertical circle scale (para 2-20).

**2-22. Circular Level**

The circular level (8, fig. 1-1) is mounted on the tribrach assembly (9, fig. 1-4). This level is used to

quickly bring the theodolite to a preliminary level position.

**2-23. Plate Level**

The plate level (6, fig. 2-3) is located at the bottom of the opening between the alidade standards. The plate level vial is graduated to aid the operator in obtaining precision leveling of the theodolite.

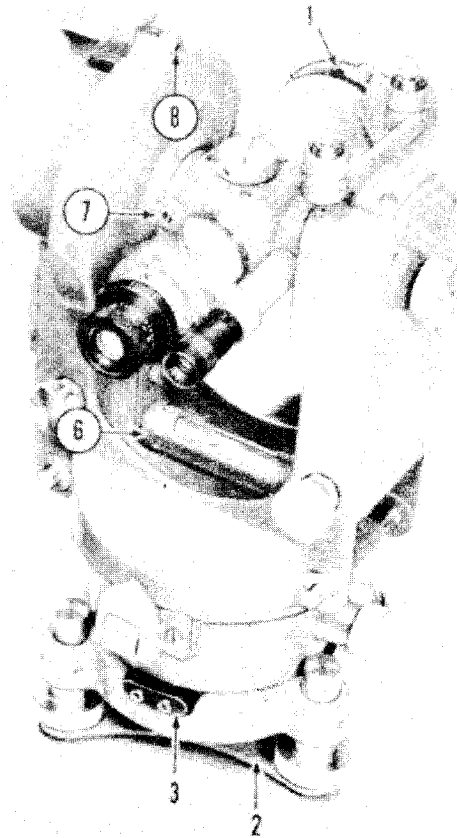
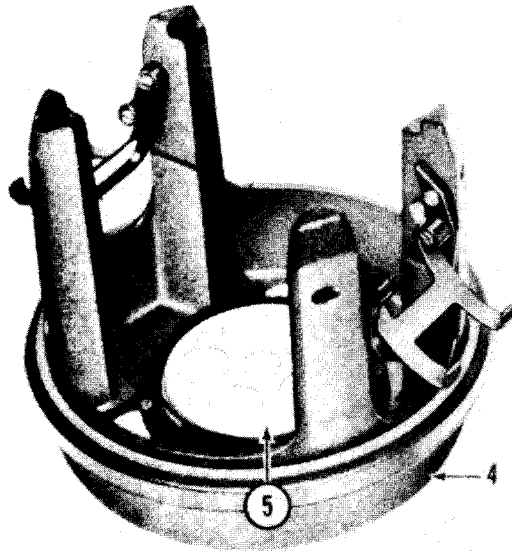

ME 6675-200-14/2-3

1. Back sight
2. Tribrach star plate
3. Alidade receptacle
4. Base assembly

5. Desiccant container
6. Plate level
7. Foresight
8. Mirror mounting

Figure 2-3. Theodolite removed from base assembly.

### 2-24. Collimation Level Mirror Assembly

The tiltable collimation level mirror assembly (1, fig. 1-2 ) is located on the upper left side of the alidade. The mirror is used by the operator to view the position of the level bubble when checking vertical collimation.

### 2-25. Installation or Setting-up Instructions

#### a. Tripod.

(1) Remove the tripod head cover (7, fig. 2-4) from the tripod head. Set the tripod (2) over the station point (5). Remove the plumb bob assembly (2, fig. 2-5) from the accessory case (6, fig. 2-4) which is mounted on the inside of one of the tripod legs. Insert the bayonet tube of the plumb bob

assembly in the hole in the bottom of the tripod bridge screw.

(2) Lock the plumb bob assembly in the bridge screw by turning the bayonet tube one-half turn. Seat the tripod feet firmly in the ground using foot pressure on the metal tripod foot shoes. Level the tripod head by adjusting the tripod legs.

#### b. Theodolite.

(1) Remove the theodolite from the carrying case (fig. 2-6) by grasping the carrying strap (1, fig. 2-6) with both hands just above the two clamping levers (3). Pull outwards, which will release the clamping levers from the base assembly (4). Remove the metal hood assembly (2) from the base assembly (4).

(2) Pull upwards on the two base clamps (2, fig. 3-2) that secure the base assembly (3) to the theodolite. Remove the theodolite from the base assembly.

(3) Lift out the desiccant container (5, fig. 2-

3) from the base assembly.

(4) Release the vertical clamp screw (12, fig. 1-3) and place the telescope (15, fig. 1-4) in horizontal position.

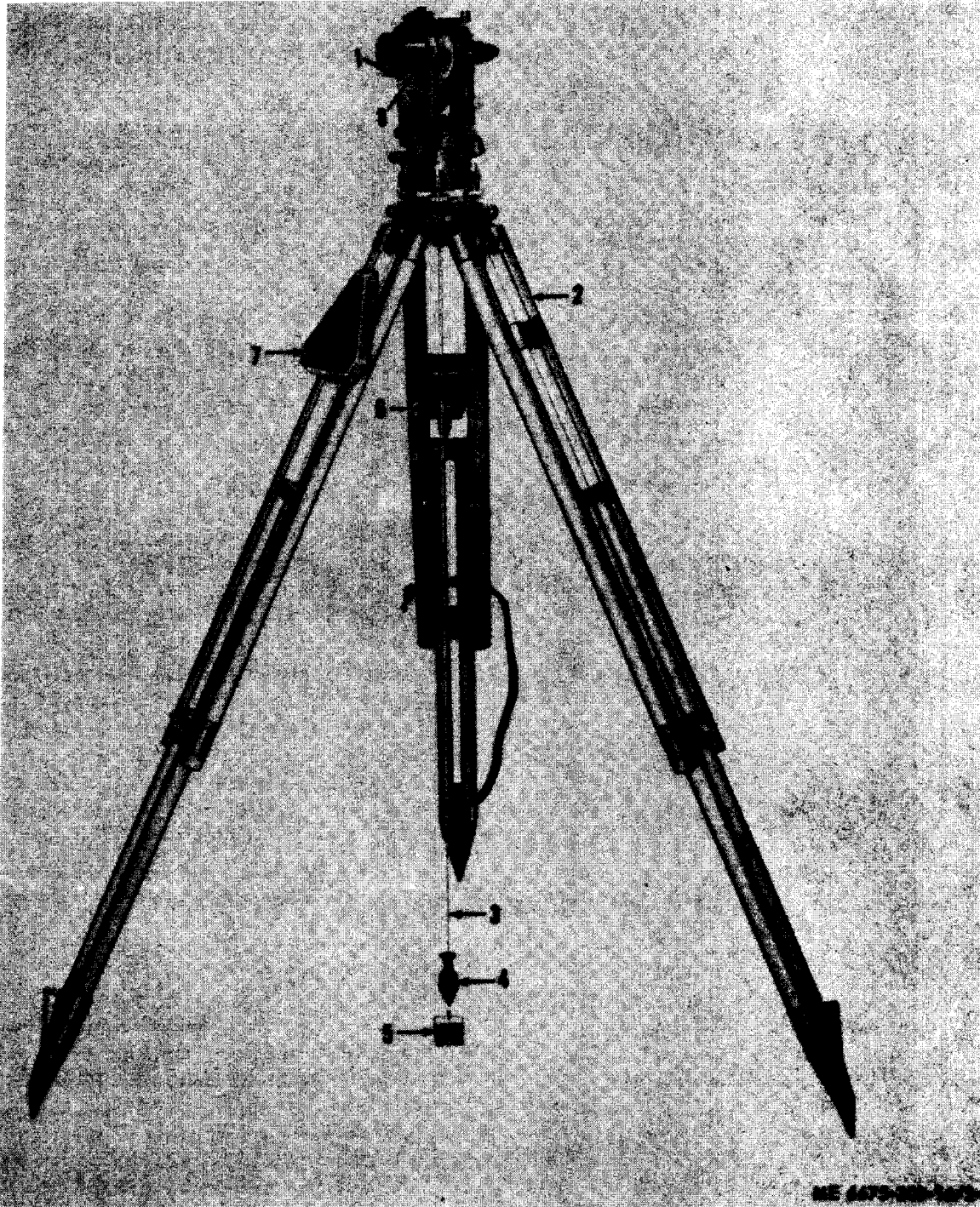

1. Theodolite
2. Tripod
3. Plumb bob cord
4. Plumb bob

5. Station point
6. Accessory case
7. Tripod head cover
8. Plug-in lamp mounting nut

Figure 2-4. Tripod and plumb bob centered on station point.

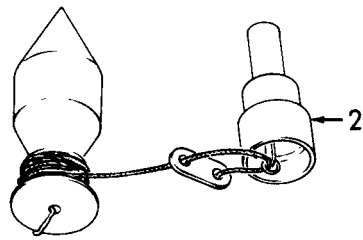
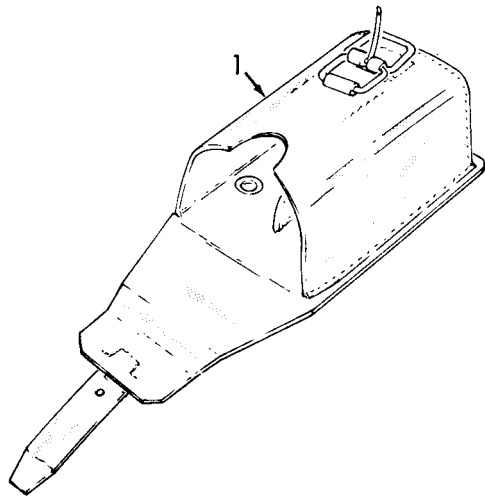

ME 6675-200-14/2-5

1. Tripod accessory case
2. Plumb bob assembly
3. Tripod wrench

Figure 2-5. Tripod accessory case and accessories, unpacked view.

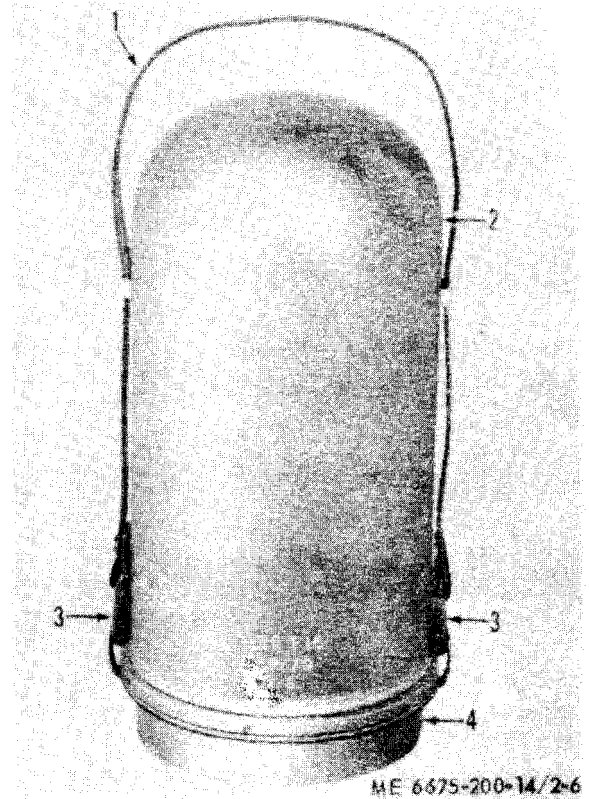

ME 6675-200-14/2-6

- |                        |                    |
|------------------------|--------------------|
| 1. Carrying strap      | 3. Clamping levers |
| 2. Metal hood assembly | 4. Base assembly   |

Figure 2-6. Theodolite in carrying case.



(5) Place the theodolite (1, fig. 2-4) on the tripod (2) so that the illumination mirror assembly (6, fig. 1-2) will receive adequate light for good operation. Secure the instrument loosely to the tripod with the bridge screw.

(6) Carefully move the instrument around the tripod head until the point of the plumb bob (4, fig. 2-4) is centered exactly over the station point (5). Tighten the instrument to the tripod head with the bridge screw, making sure the plumb bob point stays centered over the station point.

## 2-26. Operating Details

### *a. Daytime Operations.*

(1) During periods of operation when natural light is available, the illumination mirror, diagonal eyepieces, sunglasses, and circular compass are used according to the degree of light and the operating conditions. Telescope sightings and scale readings through small vertical angles from the horizontal are sighted through the conventional eyepieces (1 and 3, fig. 1-4). Large vertical angles up to  $25^\circ$  from the zenith are sighted through the diagonal eyepiece prisms. The sunglasses are provided with the instrument for zenith sightings with the telescope. The compass is normally installed on the alidade during daylight operation. However, the compass may be installed (c (10) below) and used during either daytime or nighttime operations.

(2) When operating the instrument in subterranean areas or under low light conditions, the illumination system must be installed (para 2-30).

(3) Always turn the alidade in a clockwise direction during angular measurements to attain maximum accuracy. This rule applies whether measuring from left to right, or from right to left.

### *b. Nighttime Operation.*

(1) The operator must install and use the

illumination system during nighttime operation of the theodolite (para 2-30). The scale readings are obtained during nighttime operation by lighting the vertical and horizontal circles with the illumination system (para 2-25).

(2) The illumination system, when installed, illuminates both circles, plate level, collimation level, and the telescope reticle.

(3) If the circular compass is used, a suitable nonmagnetic outside light source must be used to obtain compass azimuth readings. The operator should not attempt to use the hand lamp, since magnetic errors may result from the close proximity of the hand lamp to the compass.

### *c. Adjustments.*

#### (1) *Tripod.*

(1) Test all wood screws for firm installation. See that no play exists at the junction of the wood and metal parts. Be sure that the tripod head is not bent, burred, or scored. The clamping screws under the head must be tight enough to hold the tripod legs in position when the legs are extended and about 2 feet apart.

(b) The wing screws on the tripod legs must turn freely when loose and be kept properly lubricated to permit easy hand tightening. When the wing screws are tightened, be sure that the extension legs clamp securely to the upper tripod legs. When the wing screws are loose, the extension legs should slide easily and smoothly in the grooves in the upper legs.

(2) *Foot screws.* The foot screws (9, fig. 1-1) must turn smoothly and with moderate ease, but without backlash. Turning the foot screw adjusting screw (10, fig. 1-2) with an adjusting pin (4, fig. 2-7) increases or decreases the pressure exerted on the foot screw body. This pressure determines the ease with which the foot screw knob can be turned.

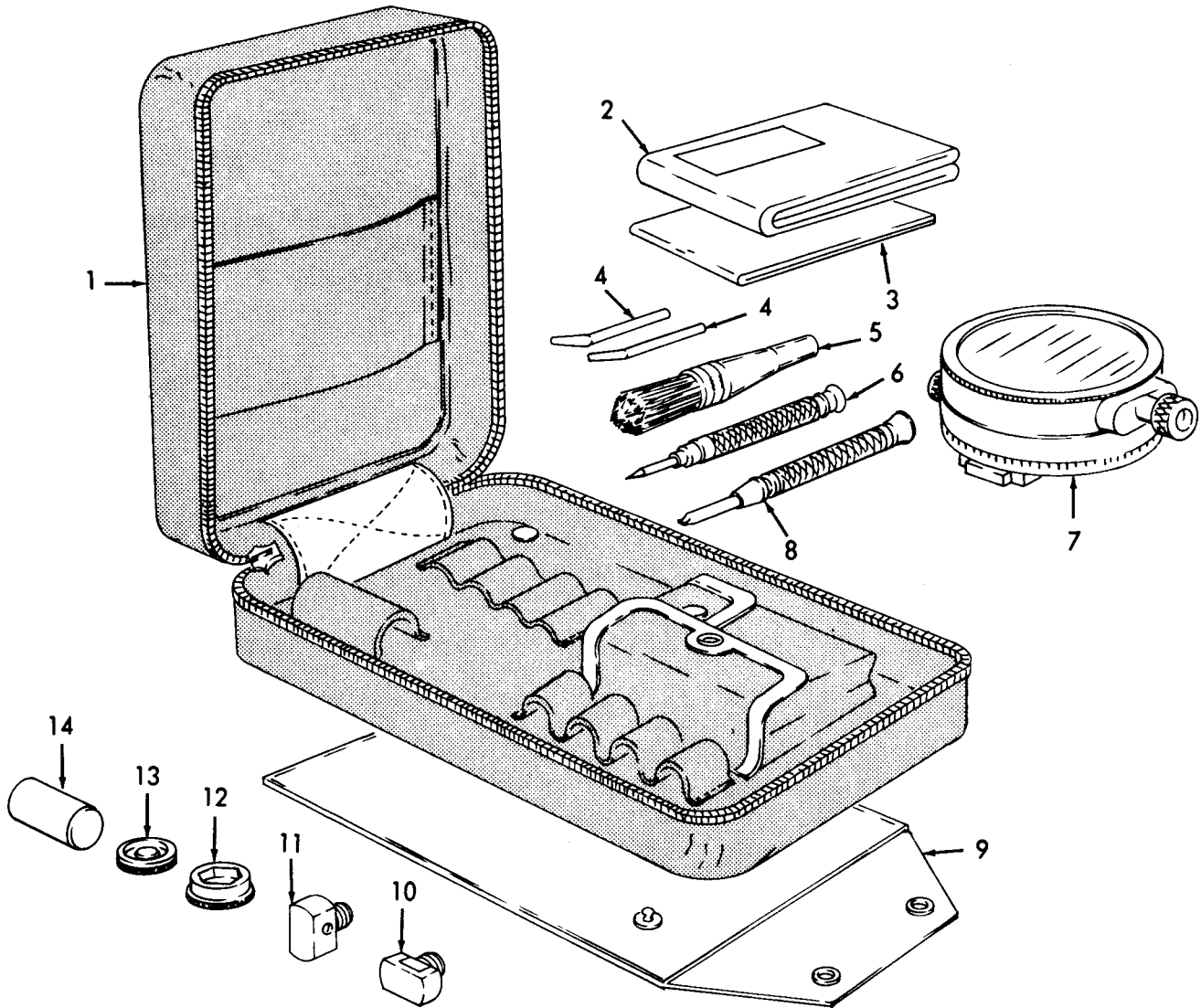

ME 6675-200-14/2-7

- |                          |  |
|--------------------------|--|
| 1. Accessory case        | 8. Screwdriver                             |
| 2. Theodolite cover      | 9. Envelope                                |
| 3. Chamois skin          | 10. Microscope diagonal eyepiece           |
| 4. Adjusting pin (2 rqr) | 11. Telescope diagonal eyepiece            |
| 5. Camel hair brush      | 12. Telescope diagonal eyepiece sunglasses |
| 6. Screwdriver           | 13. Telescope lens                         |
| 7. Compass               | 14. Lubricant container                    |

Figure 2-7. Accessory case and accessories, unpacked view.

(3) *Circular level.*

(a) Bring the bubble of the circular level

(8, fig. 1-1) to approximate center by adjusting the three foot screws (A, B, and C, fig. 2-8).

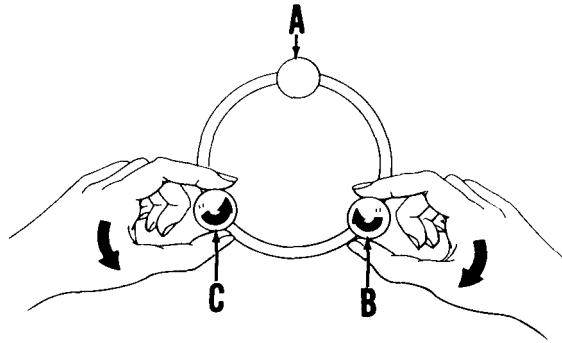

ME 6675-200-14/2-8

Figure 2-8. Leveling the theodolite with the foot screws.

(b) Check the adjustment of the circular level by completing the exact leveling of the theodolite with the plate level (6, fig. 2-3) as described in (4) (a) below. If the bubble is not centered in the black reference circle of the circular level vial window, the circular level is out of alinement.

(c) Mark the position of the bubble on the level vial window with a grease pencil or other suitable marking device for glass. Remove the theodolite from the tripod. Place the instrument on a steady support so that the circular level housing projects over the edge of the support. This will provide access to the three circular level adjusting screws in the base of the level housing. Adjust the level of the instrument with suitable shim material until the circular level bubble is alined with the temporary reference mark placed on the vial window. Now adjust the three springloaded screws in the base of the circular level housing until the bubble is centered in the regular black circle.

NOTE

The three adjusting screws should not be tightened all the way. All of them should "float" the level on the adjusting springs.

Remove the temporary reference mark previously placed on the level vial window. Install the theodolite on the tripod and bring it to exact level with the plate level. Observe the position of the circular level bubble. If it is centered in the black circle, the circular level is correctly alined. If the bubble is not centered, repeat the above procedures until the level bubble is correctly centered.

(4) *Plate level.*

(a) Level the theodolite exactly with the plate level (6, fig. 2-3). Loosen the horizontal clamp screw (8, fig. 1-3). Turn the instrument until the longitudinal axis of the plate level is parallel to any two of the foot screws, such as B and C, figure 2-8. Adjust the position of the plate level bubble by

turning foot screws B and C an equal distance in opposite directions. When the plate level bubble is centered, turn the instrument  $90^\circ$ , centering the plate level over foot screw A. Adjust this foot screw, if required, to again center the plate level bubble. Now turn the instrument  $180^\circ$ . If the bubble does not stay centered in the position, the plate level is out of alinement.

(b) Leave the instrument in the last-named position. Correct one-half of the bubble error by adjusting foot screw A.

(c) Insert an adjusting pin (4, fig. 2-7) in the plate level adjusting screw (9, fig. 1-3), and correct the other half of the error by moving the adjusting screw.

(d) Repeat the observing procedures in (a) through (c), as may be required, until the plate level bubble remains centered in any position to which the upper part of the theodolite may be turned.

(5) *Optical plumb.*

(a) With the instrument securely mounted on the tripod, carefully center and level it over a station point (5, fig. 2-4) by using the plumb bob (4) and plate level (6, fig. 2-3). Carefully remove the plumb bob and observe if the station point remains exactly in the center of the optical plumb reticle.

(b) If the station point does not remain centered in the optical plumb reticle, bring it to center by means of two adjusting screws. Remove the two cover screws (6, fig. 1-1), to the right and left of the optical plumb eyepiece and adjust the inner screws to center the optical plumb reticle on the station point. Remember that the adjusting screws move the reticle in the opposite direction of the travel of the adjusting screws. Replace the cover screws when the adjustment is completed.

(6) *Vertical collimation level mirror.* The collimation level mirror assembly (1, fig. 1-2) must

be tilted toward the operator of the theodolite during the check of vertical collimation by adjustment of the vertical collimation slow motion screw (7).

(7) *Vertical collimation slow motion screw.* The collimation slow motion screw (7) must turn easily and smoothly, but without backlash, throughout its entire travel. Use an adjusting pin (4, fig. 2-7) to turn the collimation slow motion adjusting screw (8, fig. 1-2) to make the exact adjustment.

(8) *Vertical slow motion screw.* The vertical slow motion screw (11, fig. 1-3) must turn easily and smoothly, but without backlash, throughout its entire travel. Use an adjusting pin (4, fig. 2-7) to turn the vertical slow motion adjusting screw (10, fig. 1-3), accessible just below the right side cover assembly, to make the exact adjustment.

(9) *Horizontal slow motion screw.* The horizontal slow motion screw (11, fig. 1-1) must turn easily and smoothly throughout its entire travel, but without backlash. Use an adjusting pin (4, fig. 2-7) to turn the adjusting screw (10, fig. 1-1) to make the exact adjustment.

(10) *Circular compass.*

(a) Remove the compass (7, fig. 2-7) from the accessory case (1). Install the compass on the theodolite as shown in figure 2-1, by inserting the compass legs into the compass holder (5) and tightening the locknuts.

(b) After mounting the compass, check the compass circle for tilt. Release the circle by turning

the caging knob (19) in a clockwise direction. Release the compass case by loosening the compass clamp screw (1). If the compass circle does not remain level while the case is rotated through a complete circle, correct the leveling of the the compass with one or both of the compass setscrews (13, fig. 1-3) located in the base of the compass holder (5, fig. 2-1).

## 2-27. Movement to a New Worksite

a. *Short Distances.*

(1) For short distances in cleared, level areas, the operator may carry the instrument while it is still mounted on the tripod (fig. 2-4). If the instrument is carried while mounted on the tripod, the operator should not carry it in any position other than upright.

### CAUTION

**Never carry the instrument over the shoulder.**

(2) When moving the instrument mounted on the tripod through doorways or other confining areas, the assembly should be carried in a tilting position with the tripod shoes to the rear.

b. *Long Distances.*

(1) When carrying the theodolite for long distances or over rough terrain, the instrument should be transported in the carrying case (fig. 2-6).

(2) Do not drop the carrying case into a vehicle or on the ground during transportation.

## Section II. OPERATION OF AUXILIARY EQUIPMENT

### 2-28. General

The auxiliary material used with the theodolite includes sunglasses, diagonal eyepieces, mirror assembly, battery box, and hand lamp assembly. Operation of this equipment is described in para 2-29 through 2-30.

### 2-29. Diagonal Eyepieces and Sunglasses

a. *Installation.* The diagonal eyepiece prisms (4) and telescope sunglasses (3) are installed directly on the conventional eyepieces as shown in figure 2-9. Remove the diagonal eyepiece prisms

and sunglasses from the accessory case (fig. 2-7). Install the diagonal eyepiece prisms by screwing the prism mounts on the conventional eyepieces (1 and 4, fig. 2-9) in a clockwise direction. Slip the sunglasses (3) over the telescope diagonal eyepiece prism mount.

b. *Removal.* Pull the sunglasses (3, fig. 2-9) off the telescope diagonal eyepiece prism and unscrew the diagonal eyepiece prism mounts from the telescope and microscope.

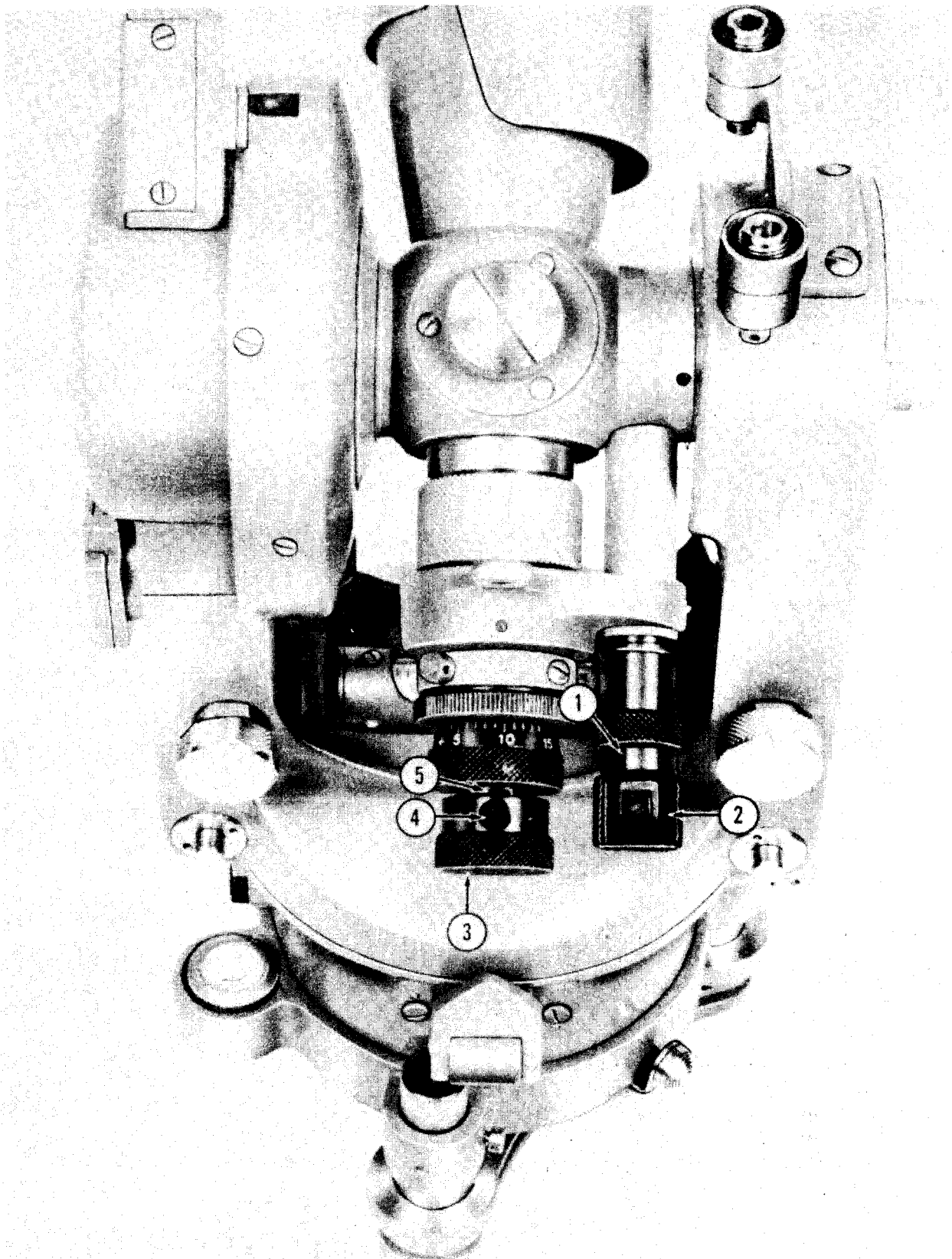

ME 6675-200-14/2-9

- |                                       |                                     |
|---------------------------------------|-------------------------------------|
| 1. Microscope eyepice                 | 4. Telescope diagonal eyepice prism |
| 2. Microscope diagonal eyepiece prism | 5. Telescope eyepiece               |
| 3. Telescope sunglasses               |                                     |

Figure 2-9. Diagonal eyepiece prism and telescope sunglasses, installed view.

## 2-30. Illumination System

### a. Installation.

(1) Remove the illumination mirror assembly (6, fig. 1-2). The assembly is a push fit on the left side cover and can be removed without difficulty.

(2) Open the battery box (3, fig. 2-10). Remove the battery cable assembly (5), hand lamp assembly (6), and plug-in lamp reflector assembly (9). Inspect the batteries (1) and dummy batteries (2) for proper installation.

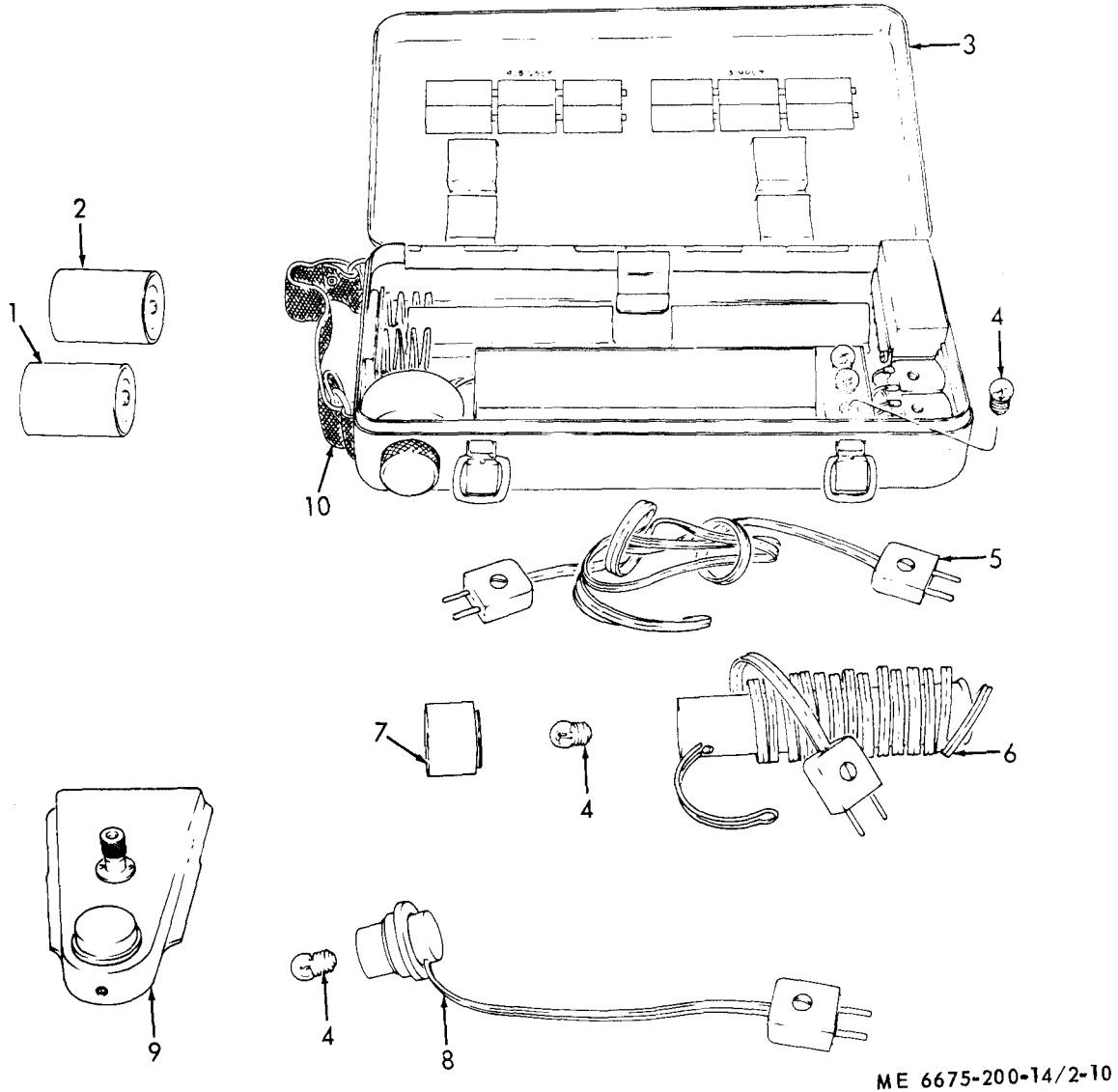

1. Battery (4 rqr)
2. Dummy battery (2) rqr)
3. Battery box
4. Lamp (5 rqr)
5. Battery cable assembly

6. Hand lamp assembly
7. Hand lamp shade
8. Plug-in lamp holder assembly
9. Plug-in lamp reflector assembly
10. Carrying strap

Figure 2-10. Battery box and accessories, unpacked view.

(3) Close the battery box (9, fig. 2-1) and mount the box on the tripod (11). Push the knob on the lower end of the battery box to the left to open the cover over the two connector receptacles in the lower end of the battery box (9). Insert one battery cable connector plug (12) in the receptacle farthest from the release knob. Insert the connector plug on the other end of the battery cable in the inner base housing receptacle (14).

(4) Insert the hand lamp connector plug (10) in the battery box receptacle nearest the receptacle cover release knob. Hang the hand lamp (13) on the tripod head cover. Lighting the hand lamp is controlled by the ON-OFF switch located on the side of the hand lamp case.

(5) Make sure that the combination switch and rheostat knob (8) is turned to its extreme counterclockwise position.

(6) Position the plug-in lamp (16) and plug-in lamp reflector (18) on the theodolite left side cover. Fasten the plug-in lamp assembly to the left side cover by screwing the mounting screw (17) into the threaded mounting nut (8, fig. 2-4).

(7) Insert the connector plug (15, fig. 2-1) of the plug-in lamp cable in the alidade connector receptacle (6).

(8) Turn the switch and rheostat knob (8) in a clockwise direction until the desired degree of illumination is obtained on both circles, the horizontal circle level, and the vertical circle level.

## CAUTION

**Conserve the life of the batteries by advancing the rheostat knob only to a position which provides sufficient illumination for operation of the instrument. Advance the setting of the knob as may be required by the ageing of the batteries.**

(1) Remove the connector plug (15, fig. 2-1) of the plug-in lamp from the alidade connector receptacle (6). Loosen the mounting screw (17) and remove the plug-in lamp and reflector from the instrument.

(2) Remove the hand lamp cable connector plug (10) from the battery box (9) and remove the hand lamp (13) from the tripod head cover.

(3) Remove the connector plugs (7 and 12) from the inner base housing receptacle (14) and the connector receptacle of the battery box (9).

(4) Remove the battery box (9) from the tripod (11). Open the battery box and replace the plug-in lamp and hand lamp assemblies. Fasten the battery box cover.

(5) Replace the illumination mirror assembly (6, fig. 1-2).

## Section III. OPERATION UNDER UNUSUAL CONDITIONS

### 2-31. General

Most surveying must be done when weather and terrain conditions are not ideal. Rough terrain, dense undergrowth, and unstable ground surfaces add to the surveyor's problems. Other factors which hinder include wide temperature variations, humidity, wind currents, and excessive sunlight. Such conditions necessitate the taking of shorter sights, greater diligence in making readings, and more maintenance must be given the theodolite.

### 2-32. Operation in Extreme Cold

With proper precautions and servicing, the theodolite can be used in extreme cold. Its use is only limited by the endurance of operating personnel and conditions affecting visibility. The instrument should be kept out of doors or in unheated buildings for short periods of non-use. Extreme changes in temperature will induce internal stresses affecting accuracy, and lenses and prisms may become fogged. Theodolites to be used under conditions of extreme cold should be cleaned and all possible lubricant removed before being put

to use. Snowfall, winds, and refraction of light are some of the difficulties encountered under low temperature conditions.

## CAUTION

**Avoid subjecting the theodolite to sudden changes in temperature.**

### 2-33. Operation in Extreme Heat

The theodolite and instrument man should be protected by a surveyor's umbrella when sights have to be taken in direct sunlight. Direct rays of the sun can cause internal stresses and distortion in the instrument. Heat waves produce poor sighting conditions. Long sights increase, and short sights decrease, the amount of sighting errors. Taking sights during the cooler early morning and late evening will also minimize error magnitude. The use of suitable dark glasses by the instrument man will reduce eye strain and fatigue. If the theodolite is kept in a cool storage place, it should be brought out of storage some time before use to allow metal temperature to approach that of the outside air.

#### **2-34. Operation in Dusty or Sandy Areas**

Special care must be taken of an instrument being used in areas where dust and sand occur. Both dust and sand are highly abrasive. If they are allowed to remain on threaded or sliding surfaces, moving parts of the theodolite will soon bind, and the instrument will become inaccurate or inoperable. The theodolite should be brushed frequently and carefully wiped clean. Be extremely careful not to scratch lens and prism surfaces during cleaning operations. Always protect the instrument from blowing dust and sand. Hood it when not in use.

#### **2-35. Operation under Rainy or Humid Conditions**

In humid areas, a slight lowering of the temperature will cause condensation of moisture and fogging of lenses and prisms. Try to keep the theodolite warmer than the surrounding air. Internal fogging can usually be removed by taking the theodolite into a warm, dry place. Corrosion, due to high humidity, can be partially eliminated by using

warm, dry storage areas and by the use of desiccants. Dry the instrument thoroughly after use and wipe the metal parts with a soft cloth lightly moistened in watch oil. Do not get any of the oil on the lens, prism, or level vial surfaces.

#### **2-36. Operation in Salt Water Areas**

Salt air is highly corrosive to many metals, particularly brass from which many theodolite parts are made. Salt, combined with brass, may produce a green deposit (verdigris) which must be guarded against and removed as soon as it is noticed. Wipe the instrument frequently with a soft cloth moistened in fresh water, and dry thoroughly. Daily, after cleaning, rub the metal parts with a cloth lightly moistened with watch oil. If the theodolite is exposed to direct salt spray it should be cleaned thoroughly, and should be returned to an instrument shop for overhauling and cleaning as soon as conveniently possible. Cleaning intervals should be shortened considerably for the theodolites when subjected to salt air exposure.



## ORGANIZATIONAL MAINTENANCE INSTRUCTIONS

## Section I. SERVICE UPON RECEIPT OF MATERIAL

**3-1. Unpacking New Equipment**

*a. General.* The theodolite is shipped in a shipping case. Unloading the instrument is easy since the loaded weight of the shipping case is

approximately 35 pounds. The shipping case door is secured by two captive screws, a hasp (3, fig. 3-1), and a padlock. The tripod and accessories are shipped in a separate shipping crate.

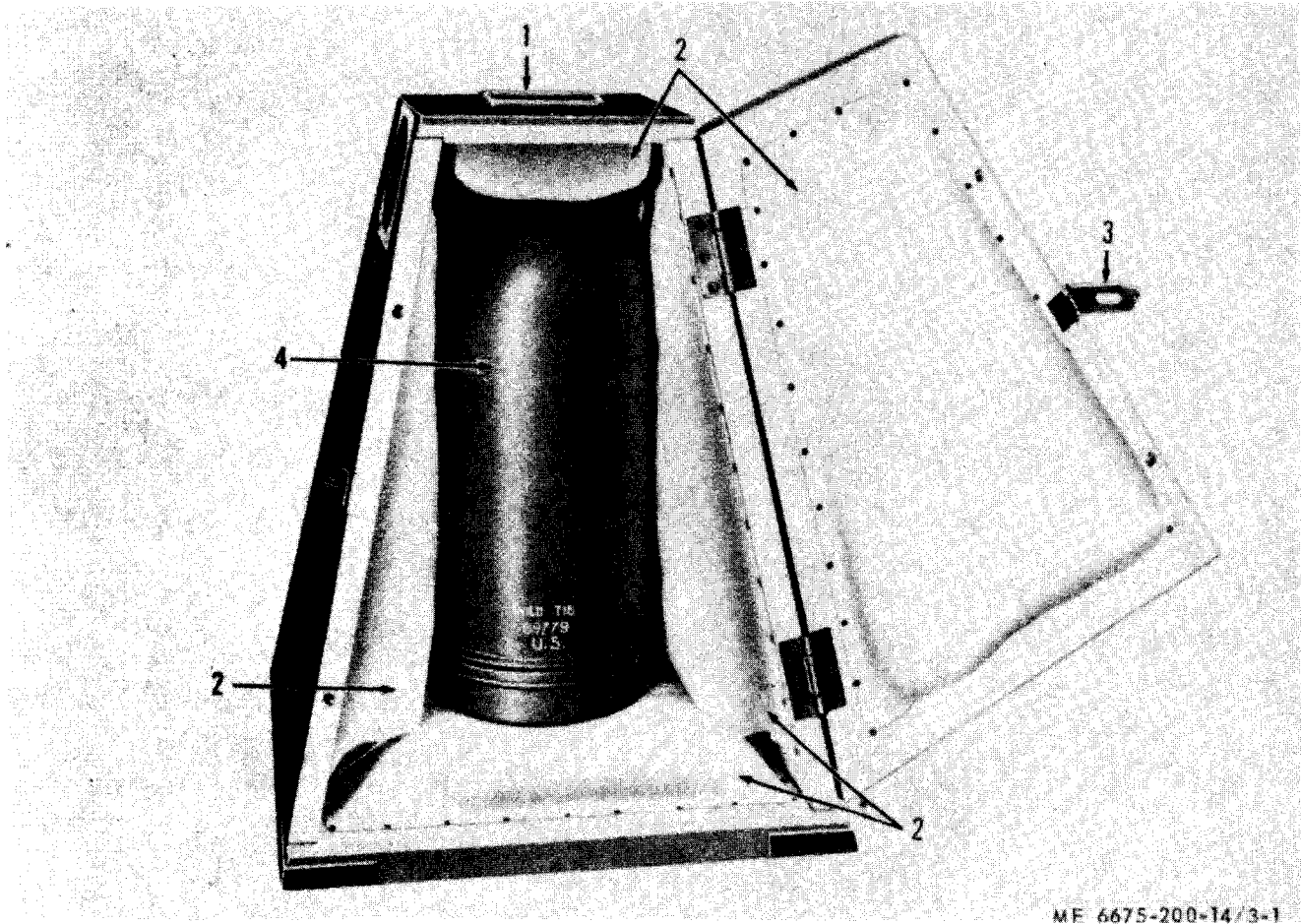

1. Carrying handle  
2. Padding

3. Hasp  
4. Carrying case

Figure 3-1. Theodolite in shipping case.

*b. Theodolite.*

(1) Lift the shipping case to a level surface with the carrying handle (1, fig. 3-1).

(2) Remove the two keys which are tied to the padlock. Unlock and remove the padlock which releases the hasp (3).

(3) Unscrew the two captive screws and open the shipping case.

(4) Grasp the carrying strap (1, fig. 2-6) at the

top of the carrying case and remove the theodolite in its carrying case from the shipping case. Place the carrying case on a firm, level surface.

(5) Grasp the carrying strap (1, fig. 2-6) with both hands just above the two clamping levers (3). Pull outwards, which will release the clamping levers from the base assembly (4). Remove the metal hood assembly (2) from the base assembly (4).

(6) Pull upwards on the two base clamps (2, fig.3-2) that secure the base assembly (3) to the

theodolite. Remove the theodolite from the base assembly.

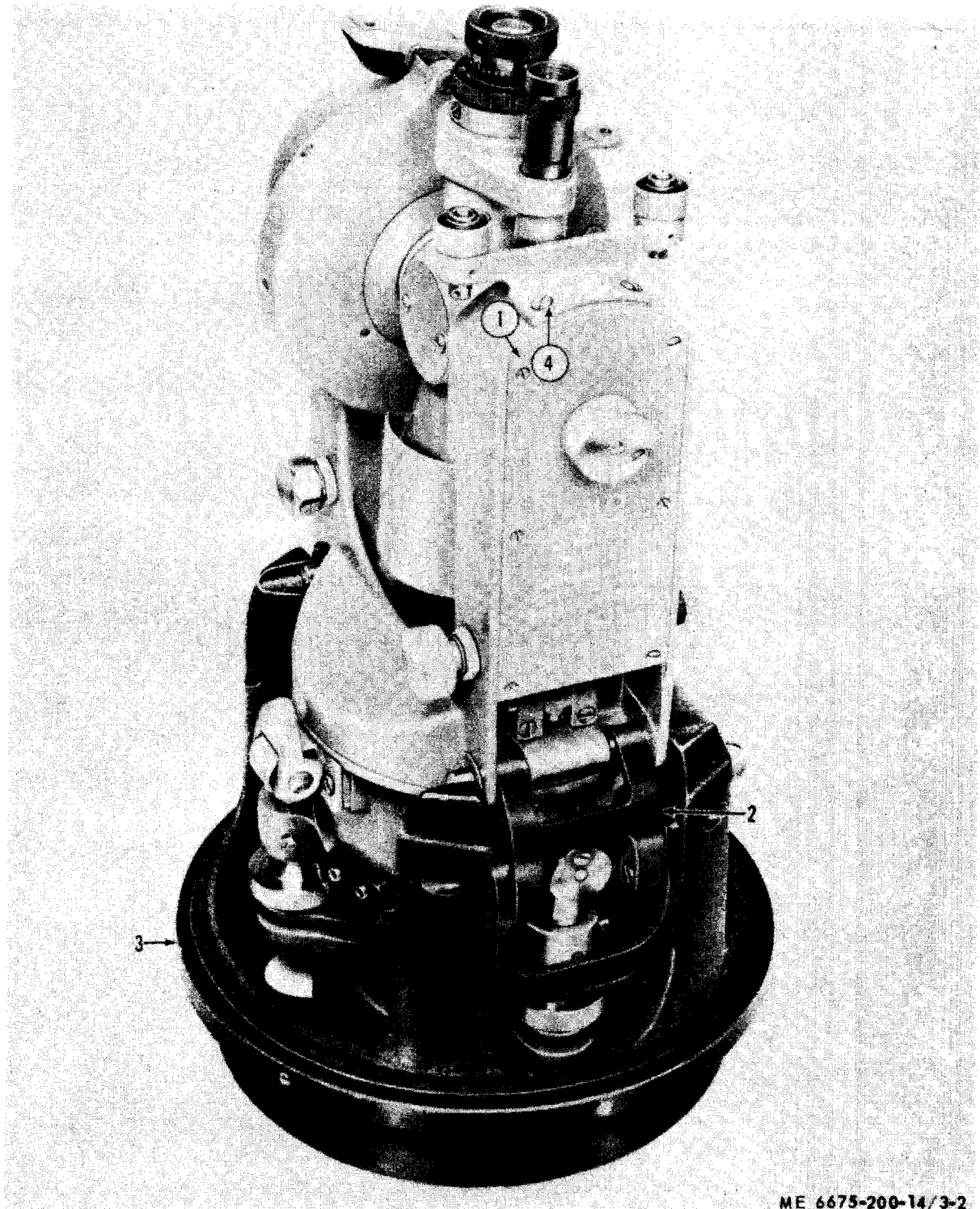

ME 6675-200-14/3-2

- 1. Alidade
- 2. Base clamp (2 rqr)

- 3. Base assembly
- 4. Screw, machine (spec) (2 rqr)

*Figure 3-2. Theodolite with metal hood assembly removed.*

(7) Lift out the desiccant container (5, fig. 2-3) from the base assembly (4).

(8) Release the vertical clamp screw (12, fig. 1-3) and place the telescope (15, fig. 1-4) in a horizontal position.

*c. Tripod Assembly.*

(1) Open the shipping crate. Remove all

braces and packing material.

(2) Remove the tripod assembly (fig. 3-3) from the shipping crate. Remove all wrapping material from the tripod assembly.

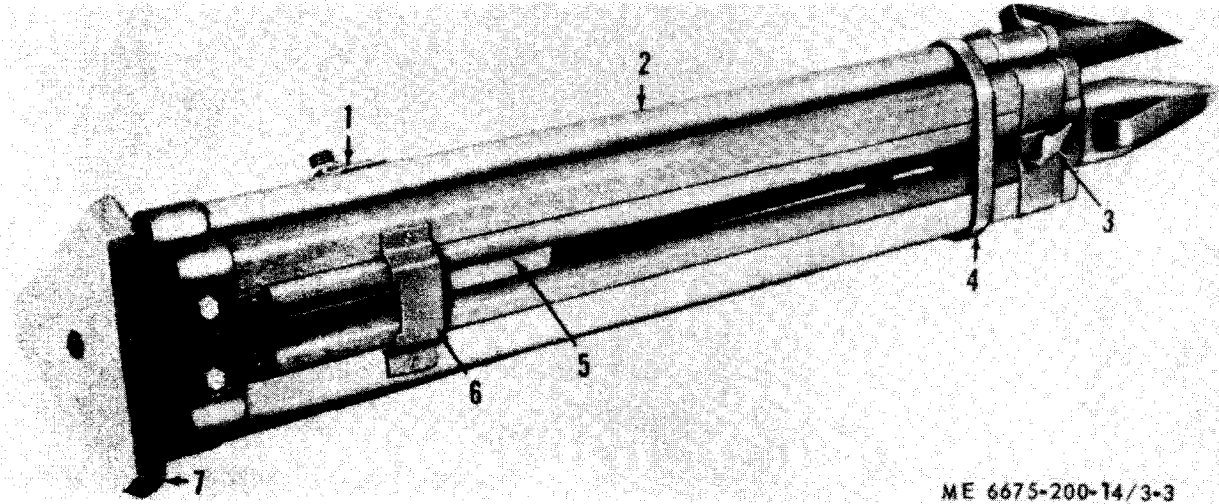

- 1. Fixing plate
- 2. Tripod leg
- 3. Leather belt
- 4. Leg clamp

- 5. Tripod accessory case
- 6. Battery box mounting bracket
- 7. Tripod head cover

*Figure 3-3. Tripod assembly, unpacked view.*

*d. Tripod Accessory Case and Accessories.*

(1) Open up the legs (2, fig. 3-3) of the unpacked tripod to permit access to the tripod accessory case (5).

(2) Open up the tripod accessory case (1, fig.

2-5) and remove the tripod wrench (3) and the plumb bob assembly (2).

*e. Field Pack.* Remove the field pack (fig. 3-4) from the shipping envelope.



ME 6675-200-14/3-4

Figure 3-4. Field pack, unpacked view.

*f. Accessory Case and Accessories.*

(1) Remove the accessory case (1, fig. 2-7) from the shipping crate.

(2) Remove all wrapping material from the accessory case.

(3) Slide down the zipper fastener and open the accessory case (1, fig. 2-7). Remove the lubricant container (14), chamois skin (3), theodolite cover (2), envelope (9), adjusting pins (4), camel hair brush (5), and screwdrivers (6 and 8) from the accessory case (1).

(4) Unfasten and open the flap covering the eyepiece pockets in the accessory case. Remove the telescope lens (13), telescope diagonal eyepiece sunglasses (12), telescope diagonal eyepiece (11), and microscope diagonal eyepiece (10).

(5) Unfasten and open, the flap covering the compass pocket. Remove the compass (7).

*g. Battery Box and Accessories.*

(1) Remove the battery box (3, fig. 2-10) from the shipping crate.

(2) Remove the shipping cover from the battery box (3, fig. 2-10).

(3) Unsnap the battery box latches and open the battery box (3).

(4) Remove the batteries (1) and dummy batteries (2), plug-in lamp assembly (8 and 9), hand lamp and shade assembly (6 and 7), and battery cable assembly (5) from the battery box (3).

**3-2. Inspection of New Equipment**

*a. Theodolite.*

(1) Inspect the carrying case (4, fig. 3-1) for

dents, cracks, and other signs of damage. Remove the theodolite from the carrying case (para 3-1), and visually inspect it for broken or missing parts, cracked or etched lenses, and any other damage. Make a photographic record, if possible, of any damage that may have occurred to the instrument during shipment. Report all damage and deficiencies to field maintenance.

(2) See that the horizontal slow motion screw (11, fig. 1-1) and vertical slow motion screw (11, fig. 1-3) turn smoothly and easily without play throughout their full travel.

(3) Inspect the horizontal clamp screw (8), vertical clamp screw (12), and horizontal circle clamp (8, fig. 1-4) for improper functioning.

(4) Inspect the lens of the objective end of telescope (15), microscope eyepiece (3), telescope eyepiece (1), and optical plumb eyepiece (5, fig. 1-1) for finger marks, dust, scratches, and etching. Remove any dust with a camel hair brush (5, fig. 2-7). If the lens or eyepieces are dirty or finger-marked, clean them with the chamois skin (3). If breathing on the glass and wiping the chamois skin does not adequately clean the lens or eyepieces, use lens tissue and grain alcohol or acetone for cleaning.

(5) Inspect the tribrach clamp lever (6, fig. 1-3) for improper functioning. The clamp lever should have sufficient tension to lock the theodolite to the tribrach assembly (9, fig. 1-4).

(6) Test the foot screws (9, fig. 1-1) for rough travel. The foot screws must turn easily with thumb and finger, but must be tight enough to hold the instrument in any position.

(7) Inspect the illumination mirror assembly (6, fig. 1-2) for improper positioning on the instrument. The mirror assembly should rotate easily on its mount, but must be tight enough to remain in any desired position.

(8) Inspect the circular level (8, fig. 1-1), plate level (6, fig. 2-3), and collimation level mirror assemblies (1, fig. 1-2) for cracks, breakage, or looseness.

(9) Inspect the telescope focusing ring (16, fig. 1-4) for improper functioning and roughness of travel. There must not be any perceptible end play.

(10) Inspect the reticle mirror knob (4, fig. 1-1) for lack of smoothness in turning throughout its travel. When the line on the top of the mirror knob is parallel to the telescope axis, the mirror does not obstruct daylight from the reticle. Turning the knob counterclockwise from the parallel position permits light to fall on the reticle.

(11) Mount the compass (7, fig. 2-7) on the compass holder (2, fig. 1-3). Inspect for improper seating and fit.

*b. Tripod.* Inspect the tripod assembly (fig. 3-3) for any damage such as a broken or missing tripod head cover (7), damaged legs (2), and cut or broken leather belt (3).

*c. Tripod Accessory Case and Accessories.*

(1) Inspect the tripod accessory case (1, fig. 2-5) for loose fit to the tripod assembly (fig. 3-3), torn leather seams, and missing or loose buckle.

(2) See if the tripod wrench (3, fig. 2-5) fits the tripod hardware.

(3) Inspect the plumb bob assembly (2) for broken or missing cords.

*d. Field Pack.* Inspect the field pack (fig. 3-4) for rips, tears, and damaged or missing straps and buckles.

*e. Accessory Case and Accessories.*

(1) Inspect the accessory case (1, fig. 2-7) for rips, tears, or a defective zipper. Be sure all inside pockets are in good condition. Inspect the theodolite cover (2) and chamois skin (3) for rips or tears.

(2) Inspect the diagonal eyepieces (10 and 11), sunglasses (12), and telescope lens (13) for improper mounting on the instrument, broken or defective glass, and uncleanness. If the glasses are dirty or fingermarked, clean with a camel hair brush (5) and chamois skin (3).

(3) Inspect the compass (7) for damage such as a broken cover glass, loose or missing hardware, and broken or missing eyepiece. See that the circle swings freely and easily on the needle screw throughout its travel. Inspect the circle caging knob for improper functioning.

(4) Inspect the two screwdrivers (6 and 8) and the two adjusting pins (4) for uncleanness and bends or cracks.

*f. Battery Box and Accessories.*

(1) Inspect the battery box (3, fig. 2-10) for dents, cracks, missing or broken clamps, and other damage. See that the lid closes easily and can be clamped securely to the box. See that all electrical contact points are securely fastened in place and are not broken or corroded. Run the rheostat knob through its travel, making sure the movement is smooth and without binding. Inspect the dummy batteries (2) for loose or dirty contacts. See that the spare lamps (4) are secure in the mounting holes and are in good condition. Inspect the carrying strap (10) for rips or tears.

(2) Inspect the hand lamp assembly (6) and battery cable assembly (5) for defective wiring or connector plugs. See that the hand lamp does not have a cracked or broken casing, defective lamp, or damaged switch.

(3) Inspect the plug-in lamp holder assembly (8) for defective wiring, lamp, or connector plug.

### **3-3. Servicing New Equipment**

*a.* Perform the preventive maintenance services described in paragraph 3-11.

*b.* Install suitable batteries in the battery box, after first making sure that they are fully charged and that the contact points are clean.

*c.* Inspect the condition of all external lenses and prisms and clean if necessary.

*d.* Be sure all accessories issued with the instrument are present and in good condition. Set the instrument on its tripod and bring it to a level position (para 2-25). Test all of the controls to be sure they are in satisfactory operating condition.

### **3-4. Used Equipment**

Perform the inspection procedures outlined in paragraph 3-2. Inspect all clamp and adjusting screws carefully for evidence of damage, binding, or corrosion. Clean all external lenses and prisms.

## **Section II. REPAIR PARTS, SPECIAL TOOLS AND EQUIPMENT**

### **3-5. Tools and Equipment**

Items troop installed or authorized for the theodolite are listed in Appendix B of this manual and TM 5-6675-200-25P.

### **3-6. Special Tools and Equipment**

The special tools required for organizational maintenance on the theodolite are listed in TM 5-6675-200-25P and the following table 3-1, Special Tools.

Table 3-1. Special Tools

| Item           | Federal stock number or part number | Reference |       | Use                               |
|----------------|-------------------------------------|-----------|-------|-----------------------------------|
|                |                                     | Fig.      | Para. |                                   |
| Screwdriver    | 5120-429-2948                       | 2-7       | 2-26  | Mounting circular compass         |
| Screwdriver    | 5120-446-2860                       | 2-7       | 2-26  | Mounting circular compass         |
| Pin, Adjusting | 6675-353-4103                       | 2-7       | 2-26  | Turn adjusting screw              |
| Wrench, Tripod | 5120-378-9520                       | 2-5       | 3-30  | Tightening down tripod head bolts |

**3-7. Repair Parts**

Repair parts required for organizational main-

tenance are listed and illustrated in TM 5-6675-200-25P.

Section III. LUBRICATION INSTRUCTIONS

**3-8. General Lubrication Information**

Any attempt to lubricate the theodolite without cleaning may result in damage to the instrument.

**NOTE**

Never perform any lubrication operation other than that specified, or use any lubricants other than those that are specifically approved to be used on the instrument.

**3-9. Detailed Lubrication Information**

*a. Care of Lubricants.* Special care should be taken to see that all surveying instrument lubricants are kept absolutely free from contamination of any foreign substance. Containers must be stored in a clean, dry place, and wiped free of dirt or dust before they are opened. All lids or bottle tops must be airtight.

*b. Lubricants.* No lubricants other than those approved for use on surveying instruments will be stocked. Approved lubricants are noncorrosive, highly refined, and must be free from any paint-removing ingredients. Ordinary machine oil is not

an approved lubricant. The following lubricants are approved for the use of this theodolite:

(1) OCW, Lubricating oil: Clock and watch (FSN 9150-252-6382)

(2) GL, Grease: aircraft and instrument (FSN 9150-576-4262)

*c. Parts Requiring Lubrication.*

(1) *Tribrach clamping lever.* Remove the tribrach assembly (9, fig. 1-4) from the theodolite. Clean all contacts on the tribrach clamp lever (6, fig. 1-3), clutch feet tension handle, and its guides. Grease all contact points sparingly with the lubricants provided in the lubricant container (4, fig. 2-7). Replace the tribrach assembly on the theodolite.

(2) *Foot screws and spike feet.* Apply grease sparingly from the lubricant container to the foot screws and the spike feet contact points. Turn each foot screw several times to distribute the lubricant over the threads.

Section IV. PREVENTIVE MAINTENANCE CHECKS AND SERVICES

**3-10. General**

To insure that the theodolite is ready for operation at all times, it must be inspected systematically, so that defects may be discovered and corrected before they result in serious damage or failure. The necessary preventive maintenance services to be performed are listed and described in paragraph 3-11. The item numbers indicate the sequence of minimum inspection requirements. Defects discovered during operation of the unit shall be noted for future correction, to be made as soon as operation has ceased. Stop operation immediately if a deficiency is noted during operation which would

damage the equipment if operation were continued. All deficiencies and shortcomings will be recorded, together with the corrective action taken, on DA Form 2024 at the earliest possible opportunity.

**3-11. Monthly Preventive Maintenance Services**

This paragraph contains a tabulated listing of preventive maintenance services which must be performed by organizational maintenance personnel. The item numbers are listed consecutively and indicate the sequence of minimum requirements. Refer to table 3-2 for the monthly preventive maintenance services.

Table 3-2. Organizational Preventive Maintenance Checks and Services

M—Monthly

Total man-hours required: 8.1

| Sequence Number                      | ITEM TO BE INSPECTED<br>PROCEDURE  | Work Time (M/ H) |
|--------------------------------------|--|------------------|
| <b>SECTION I—Accessories</b>         |  |                  |
| Man-hours required: 2.5              |  |                  |
| 1                                    | <p><b>FIELD PACK</b><br/>Inspect field pack for bears, missing buckles or straps. Clean canvas pack with soap and water and a stiff brush. Replace unserviceable pack.</p>   | 0.1              |
| 2                                    | <p><b>ACCESSORY CASE</b><br/>Inspect the accessory case, theodolite cover and publications case for cuts, tears and damaged seams. Clean all metal parts with an approved cleaning solvent. Brush clean the accessory case with a stiff bristled brush. Clean the zipper teeth thoroughly. Wipe the dirt and foreign matter from all surfaces with a soft cloth moistened in water. Replace or repair as required (para 3-43).</p>   | 0.8              |
| 3                                    | <p><b>BATTERY BOX</b><br/>Inspect the cables for cracked or damaged insulation, broken wire or defective terminals. Inspect the rheostat by rotating the knob through its travel, clockwise and counterclockwise, and check for smoothing movement. Inspect the dummy batteries for loose or dirty contacts. Check that the spare lamps are secure in the mounting holes and are in good condition. Inspect all electrical contacts points are securely fastened in place and are not broken or corroded. Replace defective parts or components (para 3-41).</p> | 1.0              |
| 4                                    | <p><b>HAND LAMP</b><br/>Inspect tube for defects, cracks or breaks. Inspect the hook ratchet for bends and damage. Inspect the lamps by plugging the hand lamp terminal into the battery box. If the lamp is defective unscrew the shade cover from the end of the light and replace the lamp with a new lamp from the battery box. Replace defective or damaged components or parts (para 3-40).</p>  | 0.1              |
| 5                                    | <p><b>CARRYING CASE (Hood Assembly)</b><br/>Inspect the metal hood for dents, cracks, and breaks. Inspect the clamping levers for excessive wear, burrs, and bends. Inspect the carrying strap for cuts and excessive wear. Replace defective carrying case. Replace defective desiccant and tools (para 3-14, 3-15).</p>  | 0.5              |
| <b>SECTION II—Tripod and Compass</b> |  |                  |
| Man-hours required: 5.0              |  |                  |
| 6                                    | <p><b>COMPASS</b><br/>Inspect the compass housing, holder clamp screw, caging knob, and eyepiece housing for bends, breaks and worn or badly damaged threads. Check that the circle swings freely and easily on the needle-screw. Clean all exterior parts of the compass with a cloth moistened with an approved cleaning solvent. Clean the eyepiece with a camel hair brush and lens tissue (para 3-32)</p>   | 3.0              |
| 7                                    | <p><b>TRIPOD</b><br/>Inspect all metal parts for cracks and wear. Inspect all threaded surfaces for excessively worn or damaged threads. Inspect the wooden legs for any cracks, splits, wear and warping. Clean all metal parts with a cloth moistened with an approved cleaning solvent. Clean all wooden parts with a soft cloth moistened with water and dry thoroughly. Clean the leg strap with a suitable leather cleaner. Replace all parts and components if damaged or broken (para 3-271).</p>  | 2.0              |
| <b>SECTION III—Alidade</b>           |  |                  |
| Man-hours required : 0.6             |  |                  |
| 8                                    | <p><b>LENSES</b><br/>Clean dirty lenses, vials, and mirrors. Replace defective objective assembly or diagonal eyepiece.</p>  | 0.5              |
| 9                                    | <p><b>SCREWS AND KNOBS</b><br/>Check adjusting screws and clamping knobs for proper operation. Adjust and / or replace faulty screws and knobs.</p>  | 0.1              |

## Section V. TROUBLESHOOTING

### 3-12. General

a. This section contains troubleshooting information for locating and correcting most of the operating troubles which may develop in the theodolite. Each malfunction for an individual component, unit, or system is followed by a list of tests or inspections which will help you to determine the probable causes and corrective actions to take. You should perform the tests / inspections and corrective actions in the order listed.

b. This manual cannot list all malfunctions that may occur, nor all tests or inspections and

corrective actions. If a malfunction is not listed or is not corrected by listed corrective actions, notify your supervisor.

### 3-13. Troubleshooting

Refer to table 3-3. This table provides troubleshooting instructions at the organizational maintenance level.

#### NOTE

Before you use this table, be sure you have performed all applicable operating checks.

Table 3-3. Troubleshooting—Organizational

| MALFUNCTION  | TEST OR INSPECTION   | CORRECTIVE ACTION |
|--|--|-------------------|
| COMPASS  |  |                   |
| 1. COMPASS CIRCLE WILL NOT ROTATE FREELY.                          | Step 1. Check for a loose caging knob.<br>Tighten knob setscrew.   |                   |
|  | Step 2. Check that compass is level.<br>Level the compass. Refer to para 2-26.   |                   |
|  | Step 3. Dull compass needle screw.<br>Replace compass needle screw (para 3-32).  |                   |
| 2. COMPASS HOUSING WILL NOT ROTATE ON COMPASS BASE.                | Step 1. Check if the clamp screw is locked.<br>Release clamp screw (para 2-9).   |                   |
| 3. REFERENCE MARK NOT CLEARLY VISIBLE.                             | Step 1. Check compass eyepiece focus.<br>Focus eyepiece (para 2-10).   |                   |
|  | Step 2. Dirty eyepiece lens.<br>Clean external lens.   |                   |
| 4. COMPASS ASSEMBLY WILL NOT SEAT PROPERLY ON THEODOLITE MOUNTING. | Step 1. Check to see if the adjusting screws in the compass mounting yoke are out of adjustment.<br>Adjust three screws (para 2-26). |                   |
| TRIPOD   |  |                   |
| 1. TRIPOD LEGS WILL NOT LOCK INTO POSITION.                        | Step 1. Check for loose tripod leg screws.<br>Tighten the screws with tripod wrench (para 2-26).                                     |                   |
|  | Step 2. Check to see if leg wing screws are damaged.<br>Replace wing screws (para 3-27).   |                   |
| 2. EXCESSIVE PLAY IN TRIPOD LEGS.                                  | Step 1. Check for loose wing screws on tripod.<br>Adjust wing screws.  |                   |
|  | Step 2. See if leg adjusting screws are out of adjustment or damaged.<br>Adjust or repair the screws.                                |                   |
| 3. THEODOLITE WILL NOT SEAT PROPERLY ON THE TRIPOD HEAD.           | Step 1. See if the bridge screw is properly started.<br>Reseat bridge screw (para 2-25).   |                   |
|  | Step 2. Check for a damaged or worn bridge screw.<br>Replace bridge screw (para 3-27).   |                   |
|  | Step 3. Check for a damaged base plate.<br>Replace the base plate (para 3-27).   |                   |
| PLATE LEVEL ASSEMBLY   |  |                   |
| 1. INSTRUMENT WIL NOT STAY ON LINE.                                | Step 1. Check for an out-of-level condition.<br>Adjust the plate level (para 2-26).  |                   |



| MALFUNCTION   | TEST OR INSPECTION  | CORRECTIVE ACTION                              |
|---|---|--|
| 2. CIRCULAR LEVEL BUBBLE DOES NOT STAY IN CENTER.               | Step 1. Check for loose level adjusting screws.                   | Tighten screws (para 2-26).                    |
| 3. COLLIMATION LEVEL BUBBLES NOT STAY IN CENTER.                | Step 1. Check if collimation slow motion screw is loose.          | Adjust the screw (para 2-26).                  |
| 4. PLATE LEVEL BUBBLE DOES NOT STAY IN CENTER.                  | Step 1. Check to see if plate level assembly is out of adjustment | Adjust the level assembly (para 2-26).         |
| ELECTRICAL SYSTEM   |   |  |
| 1. LIGHTS ON VERTICAL AND HORIZONTAL CIRCLES UNEQUAL OR ABSENT. | Step 1. Check to see if illumination mirror is out of adjustment. | Adjust mirror (para 2-26).                     |
|   | Step 2. Check malfunctioning plug-in lamp.                        | Inspect lamp for proper operation (para 2-30). |
| 2. LIGHTING SYSTEM FAULTY OR FAILS TO FUNCTION.                 | Step 1. Check for burned out lamp.                                | Replace lamp (para 2-30).                      |
|   | Step 2. Inspect if batteries are defective.                       | Replace batteries (para 2-30).                 |
| HORIZONTAL CIRCLE   |   |  |
| 1. HORIZONTAL CIRCLE DIFFICULT TO MOVE.                         | Step 1. Check if horizontal circle clamp is locked.               | Release clamp.                                 |
| TRIBRACH  |   |  |
| 1. FOOT SCREWS TOO TIGHT OR TOO LOOSE.                          | Step 1. Check for improperly adjusted foot screws.                | Adjust the screws (para 2-26).                 |
| TELESCOPE ASSEMBLY  |   |  |
| 1. TELESCOPE TURNS TOO HARD OR TOO EASILY.                      | Step 1. Check if the vertical clamp screw is improperly set.      | Reset the clamp screw.                         |

## Section VI. CARRYING CASES

### 3-14. Hood Assembly

*a. General.* The metal hood assembly (2, fig. 2-6) forms the upper part of the carrying case. The base assembly (4) forms the lower part. The carrying case provides a convenient means of carrying the theodolite in the field and serves as a dust-proof and moisture proof container for the instrument when it is in storage. The metal hood assembly is sealed to the base assembly by the pressure exerted by the two clamping levers (3).

#### *b. Metal Hood Assembly.*

(1) *Removal.* Grasp the belt (1, fig. 3-5) just above the two clamping levers (3, fig. 2-6 and pull

outward, releasing the levers from the base assembly. Lift the metal hood assembly (2) from the base assembly (4).

#### (2) *Disassembly.*

(a) Remove the lever pin (14, fig. 3-15), holding the lever spring (15) to the metal hood (17). Remove the pin holding the lever spring to the lever (16).

(b) Remove the three rivets (18) and three washers (19) and separate the lever (16) from the belt (1). Slide the belt from the belt brackets on the metal hood.

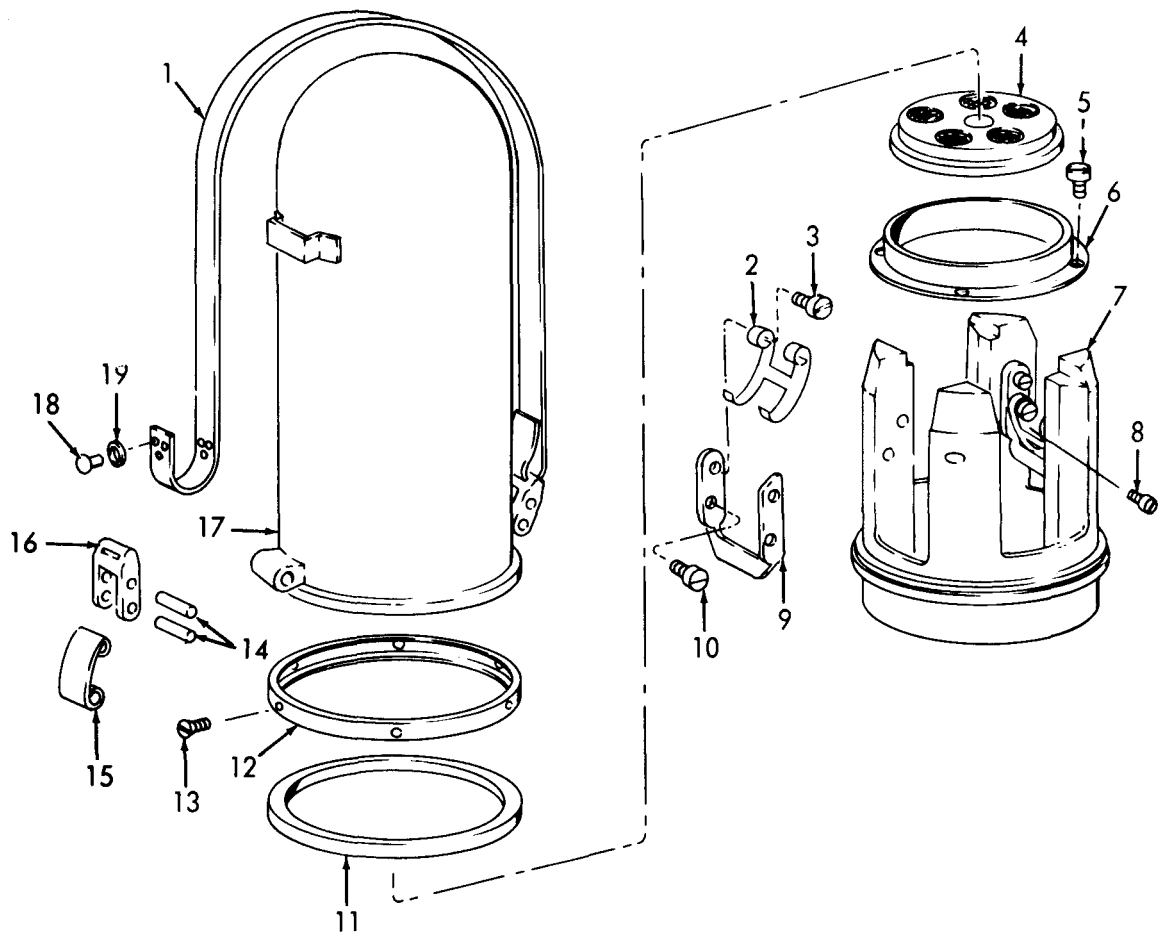

ME 6675-200-14/3-5

- |                                   |                                   |
|-----------------------------------|-----------------------------------|
| 1. Belt                           | 11. Rubber washer                 |
| 2. Hook (2 rqr)                   | 12. Collar                        |
| 3. Screw, machine (spec) (4 rqr)  | 13. Screw, machine (spec) (6 rqr) |
| 4. Desiccant container            | 14. Lever pin (4 rqr)             |
| 5. Screw, machine (spec) (4 rqr)  | 15. Lever spring (2 rqr)          |
| 6. Desiccant container plate      | 16. Lever (2 rqr)                 |
| 7. Base                           | 17. Metal hood                    |
| 8. Screw, machine (spec) (2 rqr)  | 18. Rivet (6 rqr)                 |
| 9. Lock lever (2 rqr)             | 19. Washer (6 rqr)                |
| 10. Screw, machine (spec) (4 rqr) |                                   |

Figure 3-5. Metal hood and base assemblies, exploded view.

(c) Remove the second clamp assembly in a similar manner.

(3) *Cleaning, Inspection, and Repair.*

(a) Clean all metal parts with an approved cleaning solvent. Clean the belt with saddle soap or other approved leather cleaner.

(b) Inspect the belt for cuts, cracks, and breaks. Inspect for worn mounting holes and deterioration due to age.

(c) Inspect the bins for burrs and wear. Inspect the levers for burrs, bends, and cracks. Inspect for enlarged mounting holes.

(d) Inspect the metal hood for dents, cracks, and holes. Inspect the bottom rim for out of round.

(e) Remove all burrs from the pins and levers. Straighten any minor bends. Remove any traces of rust and paint where necessary.

(f) Straighten any minor dents or bends in the metal hood. Seal any cuts or holes in the metal hood by brazing. Smooth out the brazed portion and repaint where necessary.

(g) Replace all defective parts that cannot be repaired.

(4) *Reassembly.*

(a) Thread the belt (1, fig. 3-5) through the lever (16) with the rough side of the belt next to the hood. Loop the belt through the top of the lever. Install the rivets (18) in the belt mounting holes. Install the washers (19) on the rivet ends and peen the ends.

(b) Position the lever spring (15) in the lever (16) and secure by installing a lever pin (14) in the upper mounting hole in the lever.

(c) Aline the lower mounting holes with the mounting stud on the lower part of the metal hood (17) and install the second pin (14).

(d) Install the second clamp assembly in the same manner as described above.

(5) *Installation.* Install the metal hood assembly (2, fig. 2-6) on the base plate. Engage the lower part of the clamping levers (3) under the flange on the base assembly and snap the upper portion of the clamping levers against the metal hood, locking the two together.

c. *Base Assembly.*

(1) *Removal.* Remove the base assembly (para 3-1).

(2) *Disassembly.*

(a) Remove the two machine screws (10, fig. 3-5) that secure each lock lever (9) and hook (2) to the base assembly and remove the lock levers and hooks.

(b) Remove the two machine screws (3) that secure the hooks (2) to the lock levers (9) and remove the hooks.

(c) Remove the lock lever stop screws (8) from the base (7).

(d) Remove the desiccant container (para 3-1).

(e) Remove the six machine screws (13) that secure the metal collar (12) and rubber washer (11) to the base (7) and remove the collars.

(f) Remove the four machine screws (5) that secure the desiccant container plate (6) in the bottom of the base (7) and remove the desiccant container plate.

(3) *Cleaning, Inspection, and Repair.*

(a) Clean all metal parts with an approved

cleaning solvent and dry thoroughly. Be sure that all threaded surfaces are brushed free of any foreign material. Wipe the rubber washer clean with a soft cloth.

(b) Inspect all threaded surfaces for worn or damaged threads. Inspect the levers, lever springs, and washers for burrs and worn surfaces. Inspect the base for cracks and broken casting. Inspect the metal collar for bends, breaks, and out of round. Inspect the rubber washer to see if it is damaged or hardened because of age or excessive heat.

(c) Service the desiccant container (para 3-15).

(d) Remove all burrs from the base, studs, levers, lever springs, and metal collar. Straighten minor bends in the collar and washers. Replace all defective parts.

(4) *Reassembly.*

(a) Position the desiccant container plate (6) (fig. 3-5) in the bottom of the base (7) and secure with the four machine screws (5).

(b) Position the rubber washer (11) and collar (12) on the base (7) and secure with the six machine screws (13).

(c) Install the desiccant container in the base assembly.

(d) Install the lock lever stop screws (8) in the base (7).

(e) Position the hooks (2) in the lock levers (9) and secure each with two machine screws (3).

(f) Position the hooks (2) and lock levers (9) on the base (7) and secure each with two machine screws (10).

(5) *Installation.* Install the base assembly on the theodolite and secure with the base clamps (2, fig. 3-2).

### 3-15. Desiccant Container

a. *Removal and Partial Disassembly.*

(1) Remove the metal hood and instrument from the base assembly (para 3-1). Remove the desiccant container (5, fig. 2-3) from the base assembly (4).

(2) Remove the lower container (6, fig. 3-6) from the upper container (1). Inspect the desiccant (5) to make sure that it is in good condition. Discard if defective. Remove the inner container (4) from the upper container (1) and lift out the window (3) and screen (2).

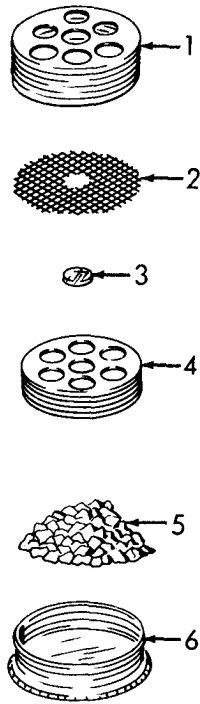

ME 6675-200-14/3-6

- |                    |                    |
|--------------------|--------------------|
| 1. Upper container | 4. Inner container |
| 2. Screen          | 5. Desiccant       |
| 3. Window          | 6. Lower container |

Figure 3-6. Desiccant container, exploded view.

*b. Cleaning and Inspection.* Clean all metal parts with an approved cleaning solvent. Inspect the window and screen for cracks and breaks. Replace defective parts.

*c. Reassembly and Installation.*

(1) *Reassembly.* Position the screen (2, fig. 3-6) in the upper container (1). Position the window (3) in the hole in the center of the screen (2). Install the inner container (4) in the upper container

(2) *Installation.* Install the desiccant container (5, fig. 2-3) in the base assembly.

(3) Install the instrument and metal hood in the base assembly (para 2-6).

### 3-16. Canvas Field Pack

The canvas field pack (fig. 3-4) should be cleaned as required with soap, water, and a stiff brush. Inspect the pack for tears, missing buckles, or straps. Replace an unserviceable pack.

## Section VII. EYEPIECES

### 3-17. General

The eyepieces used on the theodolite are the telescope and microscope eyepieces, the diagonal eyepieces, the optical plumb eyepiece, and the sunglasses. The diagonal eyepieces screw directly into the telescope and microscope eyepieces, and the sunglasses are a push fit on both the telescope eyepiece and the telescope diagonal eyepiece. The diagonal eyepieces permit sighting up to 25° from the zenith.

### 3-18. Telescope, Microscope and Optical Plumb Eyepieces

#### *a. Removal.*

(1) Remove the telescope eyepiece (1, fig. 1-4) by turning the eyepiece in a counterclockwise direction.

(2) Remove the microscope eyepiece (3) in a

similar manner.

(3) Remove the setscrew (12, fig. 1-1) that secures the optical plumb eyepiece (5) in the alidade. Remove the eyepiece (5) from the alidade by turning in a counterclockwise direction.

#### *b. Cleaning and Inspection.*

(1) Clean the eyepiece lenses with a lint-free cloth moistened with acetone or grain alcohol. Dry and polish with lens tissue.

(2) Inspect the lenses for scratches, chips, and cracks, and etching. Inspect all threaded surfaces for worn or damaged threads.

(3) Report all defects to field maintenance.

#### *c. Installation.*

(1) Install the microscope eyepiece (3, fig. 1-4) by turning the eyepiece on the microscope tube in a clockwise direction.

(2) Install the telescope eyepiece (1) on the telescope end assembly in a similar manner.

(3) Install the optical plumb eyepiece in reverse order of removal.

### 3-19. Diagonal Eyepieces

*a. Removal.* Remove the diagonal eyepieces (para 2-29).

*b. Cleaning and Inspection.*

(1) Clean the diagonal eyepieces with a lint-free cloth moistened with acetone or grain alcohol. Dry and polish with lens tissue.

(2) Inspect the eyepiece prisms for chips, cracks, scratches, or etching. Inspect the threads on the eyepieces for excessive wear or damage.

(3) Report all defects to direct support maintenance.

*c. Installation.* Install the diagonal eyepieces (para. 2-29).

### 3-20. Sunglasses

*a. Removal.* Remove the sunglasses (3, fig. 2-9) by pulling directly outwards from the telescope. Removal can be accomplished with little or no difficulty since the sunglasses are a push fit to the instrument.

*b. Cleaning and Inspection.* Clean the sunglasses with a lint-free cloth moistened with acetone or grain alcohol. Dry and polish with lens tissue. Inspect the lenses for cracks or etching. Report all defects to direct support maintenance.

*c. Installation.* Install the sunglasses (3, fig. 2-9) by pushing the glasses onto the telescope eyepiece of the diagonal telescope eyepiece. The sunglasses are a push fit.

## Section VIII. TRIBRACH, FOOT SCREW, AND STAR PLATE ASSEMBLIES

### 3-21. General

The theodolite leveling base assembly consists of the tribrach, foot screw and star plate assemblies. The assemblies enable the operator to quickly and accurately secure the theodolite to, and remove it from, the tripod head. By using it, the operator can quickly move the instrument from one station to another when closing a traverse, or making measurements where speed and extreme accuracy are required.

### 3-22. Tribrach, Foot Screw, and Star Plate Assemblies

*a. Removal.* Push the tribrach clamp lever (6, fig. 1-3) downward, and to the right (counterclockwise direction). This removes the tapered locking wedges from the tapered slots in three spike feet of the theodolite. Grasp the theodolite by the alidade (U-standard assembly) and lift the theodolite from the tribrach assembly (9, fig. 1-4).

*b. Cleaning and Inspection.* Brush all dust, dirt, and foreign matter from the tribrach components.

Wipe all surfaces clean with a soft, lint-free cloth moistened with an approved cleaning solvent. Thoroughly clean all bearing surfaces that the tapered locking wedges ride on. Inspect the tribrach, star plate, and spring plate for cracks and breaks. Inspect the foot screws for smooth operation, yet requiring a moderate amount of force by the thumb and finger to turn. Correct any deficiencies or report them to direct support maintenance. Lubricate bearing surfaces sparingly before reassembling (para 3-9).

*c. Installation.* Be sure that the clamp lever (6, fig. 1-3) is at the right end of the slot. Grasp the theodolite by the alidade U-standard. Aline the connector receptacle in the alidade receptacle (6, fig. 2-1) with the recess in the upper edge of the tribrach. Gently lower the theodolite into place in the tribrach. Lock in place by moving the clamp lever (6, fig. 1-3) to the left end of the slot.

## Section IX. MIRROR ASSEMBLIES

### 3-23. General

The rotatable illumination mirror assembly (6, fig. 1-2) is used to direct available light into the illuminating prisms within the theodolite. The tiltable collimation level mirror assembly (1) is used by the operator to check the bubble position in the vertical circle level.

### 3-24. Illumination Mirror Assembly

*a. Removal.* Grasp the illumination mirror assembly (6, fig. 1-2) firmly with the thumb and two fingers and pull outward with a twisting motion to remove the assembly from the theodolite.

*b. Cleaning and Inspection.* Clean the metal parts with an approved cleaning solvent. Clean the

mirror with a camel hair brush, if dusty, and with the chamois, if foggy. Inspect the hinge action for stiff or loose movement. Oil sparingly, if necessary, and wipe off all excess oil. Inspect the lost, cracked, or broken mirror. Inspect the metal mount for bends, cracks, and breaks. Report any deficiencies to direct support maintenance.

c. *Installation.* Push the mirror assembly (6, fig. 1-2) firmly into its mounting on the instrument.

Rotate the assembly, inspecting for snug fit in the instrument.

### 3-25. Collimation Level Mirror Assembly

The collimation level mirror assembly (1, fig. 1-2) does not require removal for cleaning and inspection. Clean the metal parts of the mirror with an approved cleaning solvent. Dry and polish the mirror with lens tissue or a soft cloth. Inspect the mirror for cracks, breaks, and dents. Report all defects to direct support maintenance.

## Section X. TRIPOD AND TRIPOD ACCESSORY CASE

### 3-26. General

The tripod provided with the theodolite has extension legs and a tripod accessory case. The accessory case is made of leather and is mounted on the tripod with wood screws. The tripod assembly consists of a triangular metal plate, with a machined metal surface; three wooden legs of the telescope type; an accessory case containing a tripod wrench and plumb bob; a metal cover to protect the machined metal plate; and the necessary hardware, and accessory supports. The theodolite is mounted on the tripod when the instrument is being used for surveying work and other precision measuring.

### 3-27. Tripod Assembly

#### a. Disassembly.

(1) Remove the tripod cover (14, fig. 3-7) by unscrewing the bridge screw (1).

(2) Remove the six screws (9) holding the tripod leg housing (10) to the tripod leg (24). Remove the six screws (8). Remove the three screws (18) from the tripod clamp screws (12).

#### CAUTION

**The three screws (18) have left hand threads.**

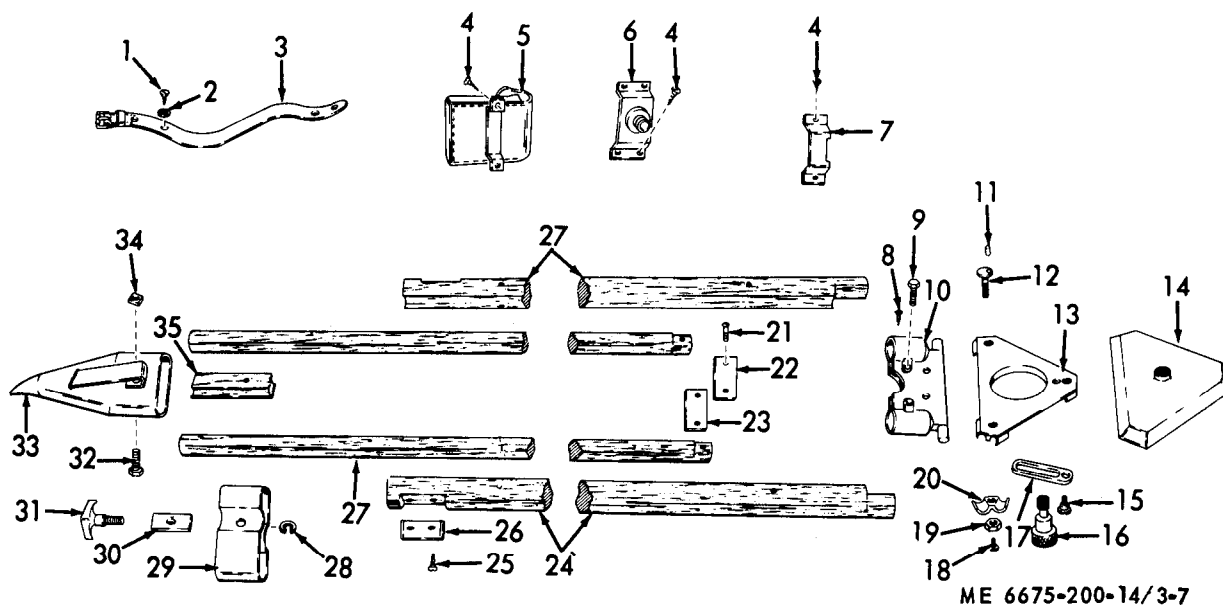

Figure 3-7. Tripod assembly, exploded view.

Key to figure 3-7:

1. Screw (2 rqr)
2. Washer (2 rqr)
3. Belt
4. Screw (8 rqr)
5. Accessory case
6. Cover fixing plate
7. Battery box bracket
8. Screw (6 rqr)
9. Screw (6 rqr)
10. Tripod leg housing
11. Taper pin (3 rqr)
12. Tripod clamp screw (3 rqr)
13. Head
14. Cover
15. Screw
16. Bridge screw
17. Bridge
18. Screw (3 rqr)
19. Hex nut (3 rqr)
20. Clamp (3 rqr)
21. Screw (6 rqr)
22. Stop plate (3 rqr)
23. Stop plate (3 rqr)
24. Upper leg (6 rqr)
25. Screw (12 rqr)
26. Guide (6 rqr)
27. Lower leg (6 rqr)
28. Spring lock (3 rqr)
29. Clamp (3 rqr)
30. Plain clamp shoe (3 rqr)
31. Wing screw (3 rqr)
32. Capscrew (3 rqr)
33. Tripod shoe
34. Nut
35. Wedge

(3) Remove the three hex nuts (19) from the tripod clamp screws (12). Remove the three clamps (20). Remove the tripod leg assembly from the tripod head assembly.

#### NOTE

The three leg assemblies are identical, with the following exceptions: The battery box bracket (7) is mounted on one leg; the accessory case (5) and belt (3) are mounted on a second leg; and the cover fixing plate (6) is mounted on the third leg

(4) Remove the two screws (21) and remove the two stop plates (22 and 23) from the lower leg (27). Remove the lower leg assembly from the upper leg assembly. Remove the two screws (4) and lift the battery box bracket (7) from the upper legs (24).

(5) Squeeze the two upper legs (24) toward each other and slide the clamp assembly (28 through 31) from the legs. Remove the spring lock (28) from the wing screw (31). Remove the wing screw (31) from the threaded clamp shoe. Remove the plain clamp shoe (30). Remove the two rivets and separate the threaded clamp shoe and clamp (29).

(6) Remove the capscrew (32) and nut (34). Tap the tripod shoe (33) from the lower legs (27). Remove the wedge (35) from the tripod shoe (33).

(7) Remove the four screws (4) and remove the cover fixing plate (6) from the second leg.

(8) Remove the two screws (4) and remove the accessory case (5) from the third leg. Remove the two screws (1) and remove the belt (3) from the third leg. Remove the two washers (2) from the belt (3).

(9) Remove the other two leg assemblies from the head (13), and disassemble them as described above.

(10) Remove the screw (5) and remove the bridge (17) from the head (13). Insert a screwdriver in the slot of the bridge (17) and pry the slot open far enough to remove the bridge screw (16) from the slot.

(11) Tap the tripod clamp screws (12) from the head (13), being careful not to damage the threads. Punch the taper pin (11) from the underside of the head of the screw (12).

#### *b. Cleaning, Inspection, and Repair.*

(1) Clean all metal parts with an approved cleaning solvent. Clean the wooden parts with a soft cloth moistened with water, and dry thoroughly. Clean the belt and accessory case with a suitable leather cleaner.

(2) Inspect the tripod leg housings and cover for burrs, cracks, and wear. Check the head for burrs, scratches, cracks, and breaks. Inspect the bridge for bends, burrs, wear, and damage. Inspect the clamps, shoes, cover fixing plate, and battery box bracket for cracks, breaks, and wear. Inspect the belt and accessory case for cuts, wear, and damaged seams. Inspect the wooden legs for cracks, splits, wear, and warping. Smooth out all burrs and minor scratches with a file. Straighten minor dents and bends. Sew damaged seams on the accessory case. Varnish the wooden legs, if the protective coating is worn or damaged. Paint any exposed metal surfaces where the metal shows because of wear or damage.

(3) Replace all defective parts that cannot be repaired.

#### *c. Reassembly.*

(1) Tap the taper pins (11, fig. 3-7) into the heads of the tripod clamp screws (12). Drive the tripod clamp screws (12) into position in the head (13), being careful not to damage the threads.

(2) Install the bridge screw (16) (knob end down) in the slot of the bridge (17), and gently tap the slot closed far enough to hold the bridge screw (16) in place. Position the bridge (17) on the head (13) and install screw (15).

(3) Place the two lower legs (27) into the tripod shoe (33) and tap the wedge (35) in place. Install capscrews (32) and nut (34). Insert the upper legs (24) into the tripod leg housing (10) and secure with the two screws (8) and two screws (9). Place the two guides (26) in the recesses of the upper legs (24) and secure with four screws (25).

(4) Rivet the threaded clamp shoe to the clamp (29) with two rivets. Insert the wing screw (31) through the plain clamp shoe (30) and clamp (29) and screw into the threaded clamp shoe. Place spring lock (28) in groove on the wing screw (31) and spring into place.

(5) Slide the assembled clamp (29) over the lower ends of the upper legs (24) until it is over the guides (26). Slide the lower legs (27) through the clamp (29) and place stop plates (22 and 23) in the recesses of the lower legs (27) and secure them with two screws (21).

(6) Assemble the other two leg assemblies as described above.

#### NOTE

The three leg assemblies are identical, with the following exceptions: The battery box bracket (7) is mounted on one leg; the accessory case (5) and belt (3) are mounted on a second leg; and the cover fixing plate (6) is mounted on the third leg.

(7) Mount battery box bracket (7) and secure with two screws (4) on one leg. Mount the accessory case (5) and install the two screws (4).

Mount belt (3) and install the two screws (1) and washers (2) on second leg. Mount the cover fixing plate (6) and install the two screws (4) on third leg.

(8) Lubricate the three tripod clamp screws (12). Place the head (13) on the three tripod housings (10) and secure it in place with three clamps (20) and three nuts (19). Lock the nuts (19) in place with three screws (18).

#### CAUTION

**The three screws (18) have left hand threads.**

(9) Adjust the three clamps (20) to hold each leg extended with the tripod shoe (33), 2 to 3 feet from the vertical.

(10) Place the cover (14) on the head (13) and insert bridge screw (16).

#### 3-28. Tripod Accessory Case

Clean the tripod accessory case with a suitable leather cleaner. Inspect the case for cuts, wear, and damaged seams. Report all defects to direct support maintenance.

### Section XI. PLUMB BOB AND TRIPOD WRENCH

#### 3-29. Plumb Bob

*a. Disassembly.* Pull the short cord (7, fig. 3-8) free from the end of the bayonet tube (1). Untie the knot in the end of the cord and pull the cord from the bottom of the bayonet tube. Remove the cord from the ring (3). Untie the knot, holding the slide (4) to the long cord (5). Remove the slide and ring from the long cord. Pull the long cord from the slot in the side of the plumb bob (6).

*b. Cleaning, Inspection, and Repair.* Clean all metal parts with an approved cleaning solvent. Inspect the plumb bob, bayonet tube, ring, and slide for signs of wear, cracks, or breaks. Inspect the lugs on the bayonet tube for burrs. Inspect the cords for wear. Use new cords when reassembling the plumb bob assembly. Replace all defective parts that cannot be repaired.



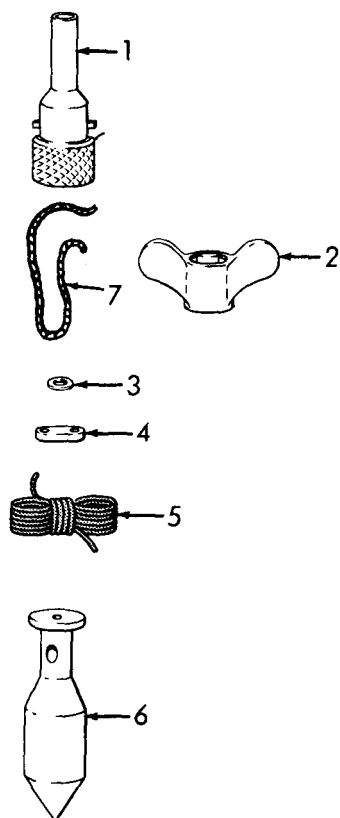

ME 6675-200-14/3-8

- |                  |               |
|------------------|---------------|
| 1. Bayonet tube  | 5. Long cord  |
| 2. Tripod wrench | 6. Plumb bob  |
| 3. Ring          | 7. Short cord |
| 4. Slide         |               |

Figure 3-8. Plumb bob and tripod wrench, exploded view.

*c. Reassembly.*

- (1) Take a piece of cord (5, fig. 3-8), 5 feet

long, and thread the free end through the hole in the top of the plumb bob (6) and out 1 of the 2 notches in the side. Pull the cord out of the notch and tie a knot in it. Pull on the free end of the long cord (5) until the knot engages the chamber in the top of the plumb bob (6).

- (2) Thread the free end of the long cord (5) through one of the holes in the slide (4). Install the ring (3) on the cord. Thread the cord back through the second hole in the slide (4). Tie a knot in the end of the cord on the underside of the slide.

- (3) Thread one end of a short cord (7) through the ring (3). Align the ends of the cord and wrap them together with a length of fine wire. Thread the free end of the wire into the large end of the bayonet tube (1) and out the hole in the top. Carefully pull the wired free ends of the short cord (7) through the hole in the top of the bayonet tube (1). Remove the wire from the cord ends and tie a knot in the free ends of the cord. When tying the knot in the short cord, be sure the looped cord is short enough so the ring hangs inside the barrel of the bayonet tube.

**3-30. Tripod Wrench**

Remove the tripod wrench (2, fig. 3-8) from the tripod accessory case (1, fig. 2-5). Clean the wrench with an approved cleaning solvent. Make a visual inspection of the wrench for evidence of wear, burrs, cracks, or breaks. Smooth out minor burrs. Inspect to see if the wrench engages the bolts on the tripod head in a satisfactory manner. Replace a defective wrench. Install the wrench in the tripod accessory case (1).

Section XII. COMPASS ASSEMBLY

**3-31. General**

The compass assembly is mounted on the top of the alidade and is held in place by the compass holder and leg, which rests on the alidade, adjacent to the collimation level mirror assembly (1, fig. 1-2) mounting point. The compass rotates on the

compass needle screw (2, fig. 3-9) and is secured in a locked position with the compass caging knob as explained in paragraph 2-8. The compass housing may be locked in any position with the compass clamp screw (para 2-9).

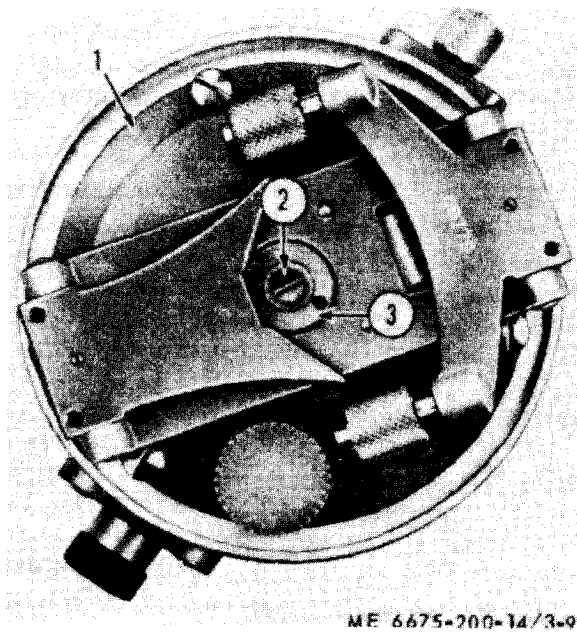

- 1. Compass base
- 2. Compass needle screw
- 3. Sleeve

Figure 3-9. Compass needle screw, removal points.

### 3-32. Compass Assembly

#### a. Removal.

(1) Remove two machine screws (4, fig. 3-2) which secure compass holder (2, fig. 1-3) to the alidade, and remove compass assembly (2, fig. 2-1) from alidade.

(2) Lock the compass housing in place with the

compass clamp screw (1).

(3) Secure the compass circle in place by releasing the compass caging knob (para 2-8).

(4) Remove compass needle screw (2, fig. 3-9) from sleeve (3) in the bottom of compass base (1) by turning it in a counterclockwise direction.

(5) Remove the two machine screws that secure the eyepiece to the compass housing. Remove the eyepiece.

*b. Cleaning, Inspection, and Repair.* Clean all exterior parts of the compass with a cloth moistened with an approved cleaning solvent. Clean the eyepiece lens with a camel hair brush (5, fig. 2-7) and lens tissue. Inspect the compass housing, holder, clamp screw, caging knob, and eyepiece housing for bends, breaks, and worn or badly damaged threads. Replace a badly worn compass needle screw. Report all other defects to direct support maintenance.

#### c. Installation.

(1) Install the eyepiece in reverse order of removal.

(2) Install compass needle screw (2, fig. 3-9) in sleeve (3) located in the bottom of the compass base (1). Secure the screw by turning it in a clockwise direction.

(3) Release the compass circle by tightening the compass caging knob (para 2-8).

(4) Release the compass housing from the locked position with the clamp screw (1, fig. 2-1).

(5) Aline the compass assembly and the compass holder on the alidade and secure with the two machine screws (4, fig. 3-2).

## Section XIII. CIRCULAR AND PLATE LEVELS

### 3-33. General

The circular level, located on the tribrach, is used to bring the theodolite into rough level during installation. The plate level, located in the lower center of the alidade, is used for more accurate leveling during installation.

### 3-34. Circular and Plate Levels

Clean the circular level (8, fig. 1-1) and plate level (6, fig. 2-3) with a cloth moistened with an approved cleaning solvent. Inspect the vials for cracks, etchings, and an old (jump) bubble. Inspect the vial cover for cracks, splits, scratches, and wear. Report all defects to direct support maintenance.

## Section XIV. ALIDADE AND OPTICAL PLUMB ASSEMBLY

### 3-35. General

The alidade is the upper part of the theodolite, including the telescope and microscope assemblies, and the vertical circle assembly. The optical plumb assembly is mounted through the lower part of the alidade, and extends downward through the horizontal circle and inner base housing assembly.

### 3-36. Alidade

Carefully clean the alidade, except the lens

assembly, with a soft cloth moistened in an approved cleaning solvent. Dry and polish with a clean, soft, dry cloth. Be sure not to get any of the solvent on the lens assembly. Brush any dust or loose dirt from the alidade with a camel hair brush (5, fig. 2-7). Inspect the alidade for bends, dents, cracks, and missing or damaged hardware. Report all defects to direct support maintenance.

### **3-37. Optical Plumb Assembly**

Clean the optical plumb eyepiece (5, fig. 1-1) with a soft cloth moistened with an approved cleaning solvent. Clean the eyepiece lens with a cloth

moistened with acetone or grain alcohol. Dry and polish with lens tissue. Visually inspect the optical plumb device for proper functioning. Report all defects to direct support maintenance.

## **Section XV. HAND LAMP, PLUG-IN LAMP, AND BATTERY BOX ASSEMBLIES**

### **3-38. General**

The hand lamp, plug-in lamp, and battery box assemblies compose the illumination system for the theodolite. The hand lamp and plug-in lamp are normally packed and transported in the battery box assembly.

### **3-39. Hand Lamp Assembly**

Clean the hand lamp assembly (6, fig. 2-10) with a cloth moistened with an approved cleaning solvent. Wipe the cables clean with a soft cloth. Inspect the tube for defects, cracks, and breaks. Inspect the hook ratchet for bends and damage. Plug the hand lamp terminal into the battery box (para 2-28) and inspect the lamp. If the lamp is defective, unscrew the shade cover (7) from the end of the light, and replace the lamp with a new lamp (4) from the battery box (3). Report all other defects to direct support maintenance.

### **3-40. Plug-In Lamp Assembly**

Clean the plug-in lamp housing with a soft cloth moistened with an approved cleaning solvent. Clean the cable with a soft cloth. Clean the lamp

window with a cloth moistened with acetone or grain alcohol. Dry and polish with lens tissue. Inspect the lamp housing for cracks or breaks. Plug the lamp into the battery box and inspect the lamp. If the lamp is defective, unscrew the lamp holder from the lamp housing and replace the lamp with a new one from the battery box. Report all other defects to direct support maintenance.

### **3-41. Battery Box Assembly**

Clean all battery box (3, fig. 2-10) metal parts with an approved cleaning solvent. Clean any corrosion from the terminals, batteries, and contacts. Brush all threaded surfaces free of dirt and foreign material. Wipe dirt and foreign matter from the cables, trunks, rheostat, springs, and washers. Inspect the cables for cracked or damaged insulation, broken wires, and defective terminals. Inspect the rheostat for proper operation and serviceability. Inspect the box for dents and breaks. Replace defective spare lamps. Report all other defects to direct support maintenance.

## **Section XVI. ACCESSORY CASE AND ACCESSORIES**

### **3-42. General**

The accessory case (1, fig. 2-7) provided with this theodolite is a canvas case containing the diagonal eyepiece (10), sunglasses (12), lubricant (14), theodolite cover (2), chamois skin (3), publications case, adjusting pins (4), screwdrivers (8), compass (7), and camel hair brush (5).

### **3-43. Accessory Case and Accessories**

Clean all metal parts with an approved cleaning

solvent. Brush the accessory case with a stiff bristled brush. Clean the zipper teeth thoroughly. Wipe the dirt and foreign matter from the publications case, theodolite cover, and camel hair brush handle with a soft cloth moistened in water and dry thoroughly. Inspect the accessory case, theodolite cover, and publications case for cuts, tears, and damaged seams. Replace all defective items.

CHAPTER 4  
DIRECT SUPPORT AND GENERAL SUPPORT  
MAINTENANCE INSTRUCTIONS

---

Section I. REPAIR PARTS, SPECIAL TOOLS AND EQUIPMENT

**4-1. Special Tools and Equipment**

The special tools or equipment required for direct and general maintenance of the theodolite are the same maintenance repair parts and special tools used by organizational maintenance (para 3-6).

**4-2. Repair Parts**

Repair parts required for direct support and general support maintenance are listed and illustrated in TM 5-6675-200-25P.

Section II. TROUBLESHOOTING

**4-3. General**

a. This section contains troubleshooting information for locating and correcting most of the operating troubles which may develop in the theodolite. Each malfunction for an individual component, unit, or system is followed by a list of tests or inspections which will help you to determine the probable causes and corrective actions to take. You should perform the tests / inspections and corrective actions in the order listed.

b. This manual cannot list all malfunctions that may occur, nor all tests or inspections and

corrective actions. If a malfunction is not listed or is not corrected by listed corrective actions, notify your supervisor.

**4-4. Troubleshooting**

Refer to table 4-1. This table provides troubleshooting instructions at the direct and general maintenance levels.

NOTE

Before you use this table, be sure you have performed all applicable operating checks.

*Table 4-1. Troubleshooting—Direct Support and General Support*

---

| MALFUNCTION        |
|--------------------|
| TEST OR INSPECTION |
| CORRECTIVE ACTION  |

---

LEVEL BUBBLE

1. CIRCULAR LEVEL BUBBLE DOES NOT STAY IN CENTER.  
Step 1. Check to see if level bubble jumps.  
Replace the level (para 4-7).
2. COLLIMATION LEVEL BUBBLE DOES NOT STAY IN CENTER.  
Step 1. Check to see if collimation level is loose.  
Adjust and tighten the screws (para 4-5).
3. PLATE LEVEL BUBBLE DOES NOT STAY IN CENTER.  
Step 1. Check to see if level bubble jumps.  
Tighten the plate level screws (para 4-6).

ILLUMINATION SYSTEM

1. BATTERIES WILL NOT HOLD CHARGE.  
Step 1. Inspect cables for cracked or damaged insulation.  
Tape cracked insulation (para 4-10).
2. HAND LAMP DIM OR UNSTEADY.  
Step 1. Check for corroded contacts and broken terminals.  
Clean or replace terminals and contacts (para 4-11).

### Section III. GENERAL MAINTENANCE

#### 4-5. Vertical Collimation Level

##### a. Removal.

(1) Remove the two machine screws (3, fig. 1-2) which secure the collimation level cover (2) on the alidade. Remove the level cover.

(2) Remove the three machine screws (2, fig. 4-1) which secure the vertical collimation level assembly to the vertical collimation housing (3). Remove the collimation level assembly (1).

b. Installation. Install the level assembly in reverse order of removal.

##### c. Adjustment.

(1) Loosen the three machine screws (2, fig. 4-1) slightly.

(2) Level the theodolite (para 2-26).

(3) Set the telescope in a horizontal position.

(4) Set the vertical circle at 1,600 mils with the vertical collimation slow motion screw.

(5) Turn the adjusting screw (11) until the movable end of the level beam (13, fig. 4-2) is at the center of its travel in the level housing (5).

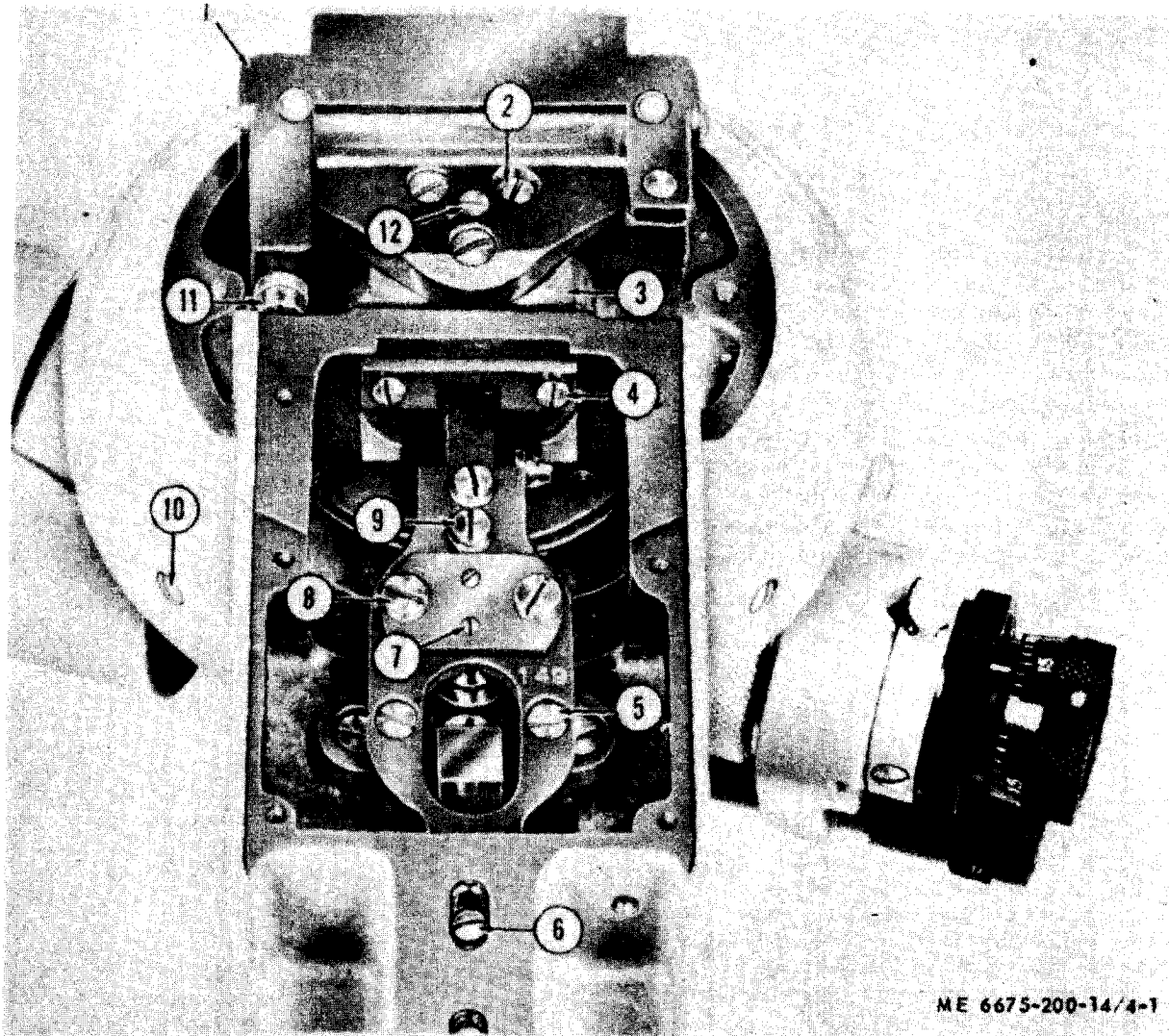

1. Vertical collimation level assembly
2. Screw, machine (spec) (3 rqr)
3. Vertical collimation housing
4. Screw, machine (spec) (2 rqr)
5. Screw, machine (spec) (2 rqr)
6. Screw, machine (spec) (4 rqr)

7. Screw, machine (spec) (2 rqr)
8. Screw, holding (spec) (2 rqr)
9. Screw, machine (spec) (2 rqr)
10. Screw, machine (spec) (4 rqr)
11. Screw, adjusting (spec)
12. Screw, machine (spec)

Figure 4-1. Vertical collimation level, vertical collimation lever and illumination lens assemblies, removal points.

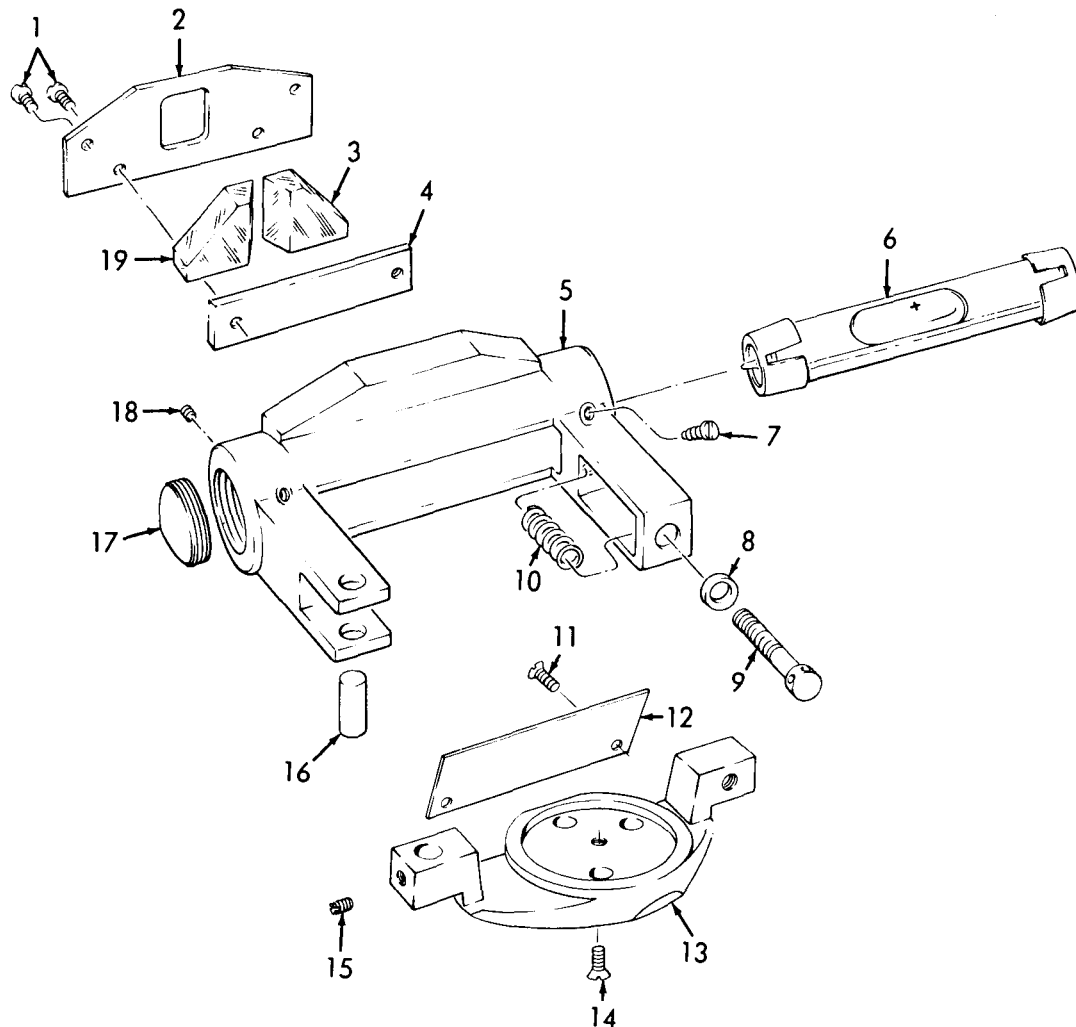

ME 6675 -200-14/4-2

- |                                  |                                   |
|----------------------------------|-----------------------------------|
| 1. Screw, machine (spec) (4qr)   | 11. Screw, machine (spec) (2 rqr) |
| 2. Plate                         | 12. Reflector (window)            |
| 3. Right side prism              | 13. Level beam                    |
| 4. Metal prism                   | 14. Screw, machine (spec)         |
| 5. Level housing                 | 15. Setscrew                      |
| 6. Level housing                 | 16. Pin                           |
| 7. Screw, machine (spec) (6 rqr) | 17. Cover                         |
| 8. Washer                        | 18. Setscrew                      |
| 9. Screw, adjusting (spec)       | 19. Left side prism               |
| 10. Helical compression spring   |                                   |

Figure 4-2. Collimation level assembly, exploded view.

(6) Shift the vertical collimation level assembly (1, fig. 4-1) slightly by hand until the collimation level bubble is approximately centered.

(7) Tighten the three machine screws (2) moderately.

(8) Center the level bubble accurately with the adjusting screw (11).

(9) Replace the vertical collimation level cover.

#### 4-6. Plate Level

##### a. Removal.

(1) Remove the four plate level mounting screws (5, fig. 1-3) that secure the plate level bearing to the right side of the alidade.

(2) Pull out the plate level assembly from the right side of the alidade.

##### b. Cleaning and Inspection.

(1) Clean all metal parts with an approved cleaning solvent. Clean glass level with soft cloth or tissue.

(2) Remove all burred edges with a swiss pattern file. Paint all surfaces where the paint is worn away or chipped.

*c. Installation.* Install in reverse order of removal.

#### **4-7. Circular Level**

*a. Removal.* Remove the three machine screws that secure the circular level (8, fig. 1-1) to the tribrach (9, fig. 1-4).

#### **CAUTION**

**Be sure to hold the circular level assembly securely in place while removing the three machine screws to prevent possible breakage.**

*b. Cleaning and Inspection.*

(1) Clean all metal parts with an approved cleaning solvent. Clean glass level with soft cloth or tissue.

(2) Remove all burred edges with a swiss pattern file. Paint all surfaces where the paint is worn away or chipped.

*c. Installation.* Install in reverse order of removal.

#### **4-8. Illumination Mirror Assembly**

*a. Removal.* Remove the illumination mirror assembly (6, fig. 1-2) from the left side support cover as outlined in paragraph 3-24.

*b. Disassembly*

(1) Remove the threaded retaining bushing (8, fig. 4-3) from the threaded sleeve (15) by turning the bushing in a counterclockwise direction.

(2) Remove the retaining clip (9) from the sleeve (15).

(3) Remove the machine screw (12) which adjusts the tension on the mirror axis pin (11).

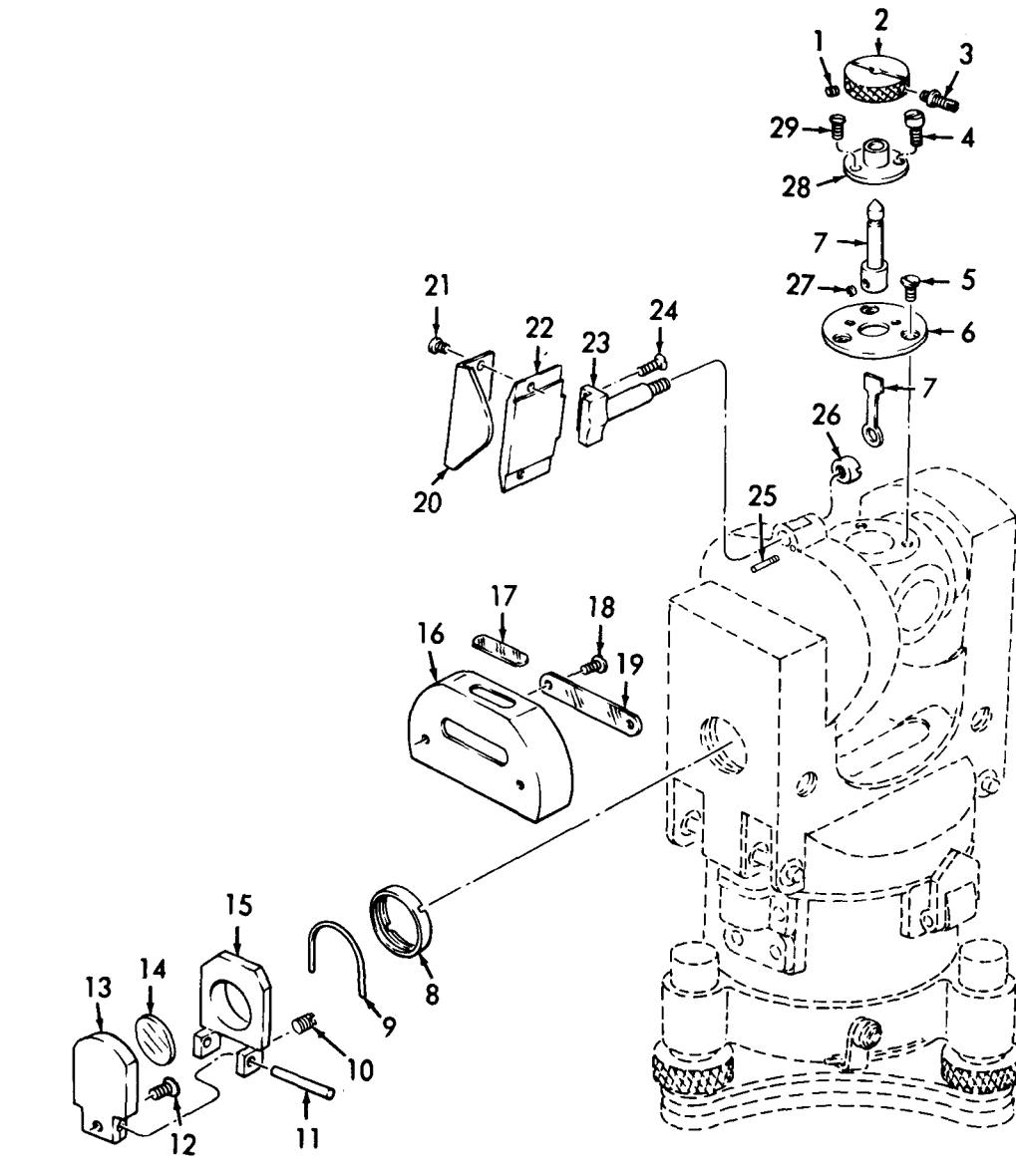

ME 6675-200-14/4-3

- |                           |                                    |
|---------------------------|------------------------------------|
| 1. Setscrew (2qr)         | 16. Collimation level cover        |
| 2. Knob                   | 17. Upper window                   |
| 3. Stop                   | 18. Screw, machine (2 rqr)         |
| 4. Screw, machine (2 rqr) | 19. Side window                    |
| 5. Screw (3 rqr)          | 20. Collimation level mirror cover |
| 6. Cover                  | 21. Screw, machine (2 rqr)         |
| 7. Mirror shaft           | 22. Mirror                         |
| 8. Threaded bushing       | 23. Mirror axis                    |
| 9. Retaining clip         | 24. Screw, machine (2 rqr)         |
| 10. Setscrew              | 25. Stop screw                     |
| 11. Pin                   | 26. Nut                            |
| 12. Screw, machine        | 27. Setscrew                       |
| 13. Mirror housing        | 28. Bearing                        |
| 14. Mirror                | 29. Screw                          |
| 15. Sleeve                |                                    |

Figure 4-3. Collimation level mirror and level cover, illumination mirror, and reticle mirror assemblies, exploded view.



(4) Remove the setscrew (10) that secures the axis pin (11) in the mirror housing (13).

(5) Remove the pin (11) from the mirror housing (13).

(6) Remove the mirror housing (13) and mirror (14).

#### NOTE

The mirror is cemented in the mirror housing and cannot be removed unless the cement is carefully softened with alcohol.

#### *c. Cleaning, Inspection, and Repair.*

(1) Clean all metal parts with an approved cleaning solvent.

(2) Clean the mirror by breathing on it and polishing with a chamois skin, lens tissue, or soft cloth.

(3) Inspect the mirror for cracks, breaks, and loose backing. Inspect the mirror housing and sleeve for bends, cracks, and scored bearing surfaces.

(4) Inspect the pin for wear and scored surface. Remove burred edges with a swiss pattern file and smooth out minor dents.

(5) If the mirror is damaged, replace it. Cement it in place in the mirror housing with shellac. Allow it to dry thoroughly after carefully wiping off any excess shellac.

#### *d. Reassembly.*

(1) Position the mirror housing (13, fig. 4-3) in the sleeve (15) and install the axis pin (11) in the assembly.

(2) Install the setscrew (10) to secure the pin (11).

(3) Install the machine screw (12) in the mirror housing (13) and adjust the tension on the axis pin (11).

(4) Install the retaining clip (9) in the sleeve (15).

(5) Install the threaded retaining bushing (8) on the threaded sleeve (15) by turning in a clockwise direction.

*e. Installation.* Install the illumination mirror assembly on the theodolite as outlined in paragraph 3-24.

## Section IV. ILLUMINATION SYSTEM

### **4-9. General**

The illumination system is used to make night reading of the plate and collimation levels and to illuminate the horizontal and vertical circles. The hand lamp is used to illuminate the circular level and to provide general illumination for the nighttime operation of the theodolite.

#### **CAUTION**

**Do not use the hand lamp in close proximity to the compass.**

### **4-10. Battery Box Assembly**

#### *a. Disassembly.*

(1) Remove the screw (11, fig. 4-4) and disconnect the two contacts (10). Remove the two nuts (5) and washers (4) and lift the contact springs (3), contact (2), and insulation (1) from the studs inside the battery box (33).

(2) Remove the taper pin (36) and setscrew (34) from the rheostat knob (35). Remove the

holding washer (37) and separate the rheostat (9) from the battery box (33). Unsolder the cable (8) from the rheostat (9). Remove the two screws (31) and lift out the trunk (30).

(3) Remove the screw (11) and lift the contact (10) from the battery contact (22). Remove the two screws (13) and lift the two sockets (14) from the battery box. Remove the four setscrews (15) and separate the cables (8 and 12) from the sockets. Bend down the wire clips and lift the cables (8 and 12) from the battery box (33).

(4) Remove the two screws (31) and lift the trunk (23) part way from the battery box. Remove the screw (26) releasing the spring (25) from the trunk. Remove the three screws (21) and separate the battery contact (22) from the trunk.

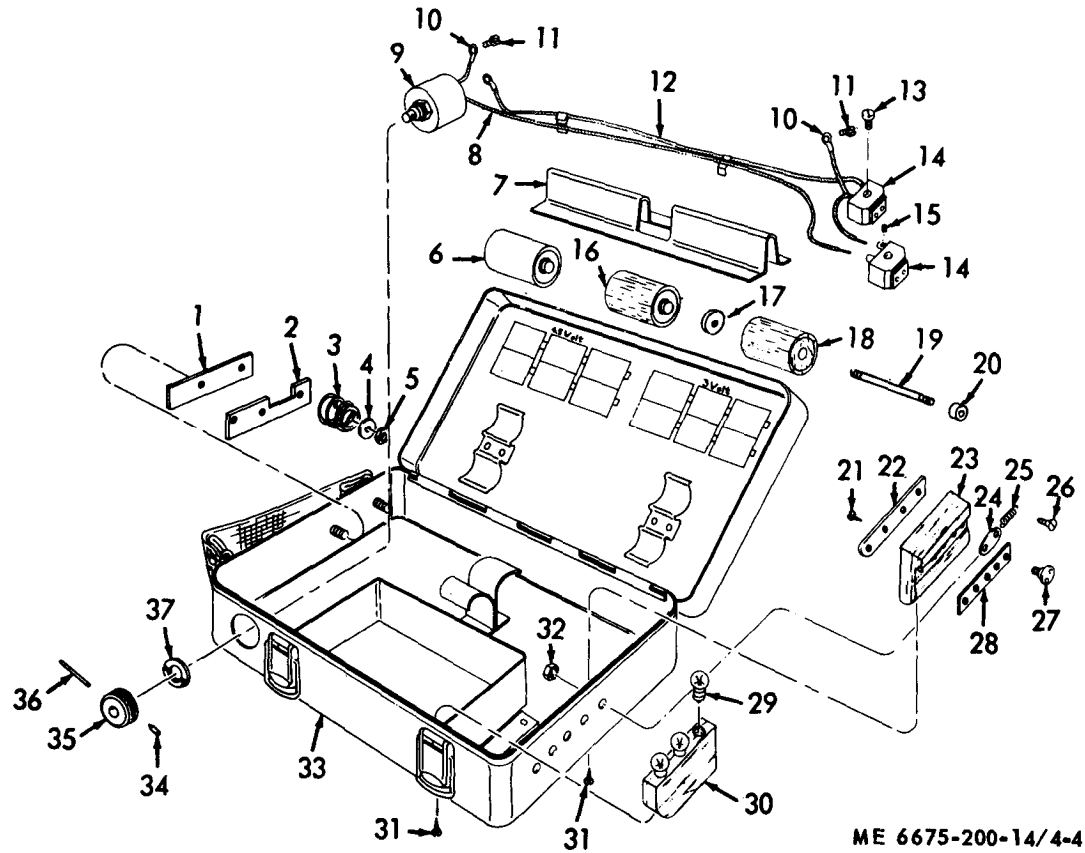

ME 6675-200-14/4-4

- |                           |                     |
|---------------------------|---------------------|
| 1. Insulation             | 20. Nut             |
| 2. Contact                | 21. Screw (3 rqr)   |
| 3. Contact spring (2 rqr) | 22. Battery contact |
| 4. Washer (2 rqr)         | 23. Trunk           |
| 5. Nut (2 rqr)            | 24. Link contact    |
| 6. Battery                | 25. Spring          |
| 7. Separator washer       | 26. Screw           |
| 8. Cable                  | 27. Knob            |
| 9. Rheostat               | 28. Slide lever     |
| 10. Contact (3 rqr)       | 29. Lamp (5 rqr)    |
| 11. Screw (2 rqr)         | 30. Trunk           |
| 12. Cable                 | 31. Screw (4 rqr)   |
| 13. Screw (2 rqr)         | 32. Nut             |
| 14. Socket (2 rqr)        | 33. Battery box     |
| 15. Setscrew (4 rqr)      | 34. Setscrew        |
| 16. Dummy battery         | 35. Rheostat knob   |
| 17. Nut                   | 36. Taper pin       |
| 18. Body                  | 37. Holding washer  |
| 19. Stud                  |                     |

Figure 4-4. Battery box, exploded view.

(5) Remove the nut (32) and remove the knob (27), slide lever (28), link contact (24), and spring (25). Remove the spring from the link contact.

(6) Remove the separator washer (7) from the battery box.

*b. Cleaning, Inspection, and Repair.*

(1) Clean all metal parts with an approved cleaning solvent. Remove all corrosion from terminals and contacts. Wipe dirt and foreign matter

from the cables, trunks, rheostat, springs, and washers. Clean the battery box with a soft rag moistened with cleaning solvent and wipe dry.

(2) Inspect the cables for cracked, swollen, or damaged insulation, broken wires, and defective terminals. Inspect the springs for bends, breaks, and fatigue. Inspect the trunks for splits, cracks, and other damage. Inspect the sockets for cracks and damage. Inspect the washers for cracks and

wear. Inspect the contacts and slide lever for burrs, bends, and wear. Inspect the battery box for bends, cracks, and defective clamps. Inspect the screws and pins for burrs and damaged threads.

(3) Tape cracked insulation on cables. Stretch slightly fatigued springs to provide better holding tension. Smooth out all burred surfaces with a fine file. Straighten minor bends. Paint all worn surfaces where the metal is exposed. Replace all defective parts that cannot be repaired.

*c. Reassembly.*

(1) Slide the shaft of the rheostat (9, fig. 4-4) through the mounting hole in the side of the battery box (33). Install the holding washer (37). Turn the shaft of the rheostat counterclockwise as far as it will go. Position the rheostat knob (35) on the shaft, alining the slot in the knob with the black line on the end of the battery box (33). Aline the hole in the shaft with the hole in the rheostat knob and install the taper pin (36). Install the setscrew (34).

(2) Position the cables (8 and 12) in the battery box (33) and install the two clamps. Solder the cable (8) to the rheostat (9).

(3) Assemble the insulation (1) and contact (2) on the studs in the battery box. Position the two contact springs (3) and secure with the two washers (4) and nuts (5).

(4) Position the contact (10), on the lead from the rheostat (9) and cable (12), on the contact (2)

and install the screw (11). Position the ends of the two cables (8 and 12) and the connector cable in the two sockets (14) and secure with the four setscrews (15).

(5) Position the two sockets (14) in the battery box (33) and secure with the two screws (13). Hook up the spring (25) to the link contact (24) Position the slide lever (28) and connect the link contact to the slide lever with the knob (27) and nut (32). Install the battery contact (22) on the trunk (23) using the three screws (21).

(6) Install the connector cable to the battery contact (22) with the screw (11). Install the screw (26) in the trunk (23) and connect the spring (25). Position the trunk (23) in the battery box (33) and secure with the two screws (31).

(7) Position the trunk (30) in the battery box and secure with the two screws (31). Install the separator washer (7) in the battery box (33).

#### **4-11. Hand Lamp and Cable Assembly**

*a. Disassembly.*

(1) Remove the shade tube (20, fig. 4-5) from the body tube (24). Remove the screw (23) which holds the lamp insulation (15) and hook ratchet (13) to the body tube.

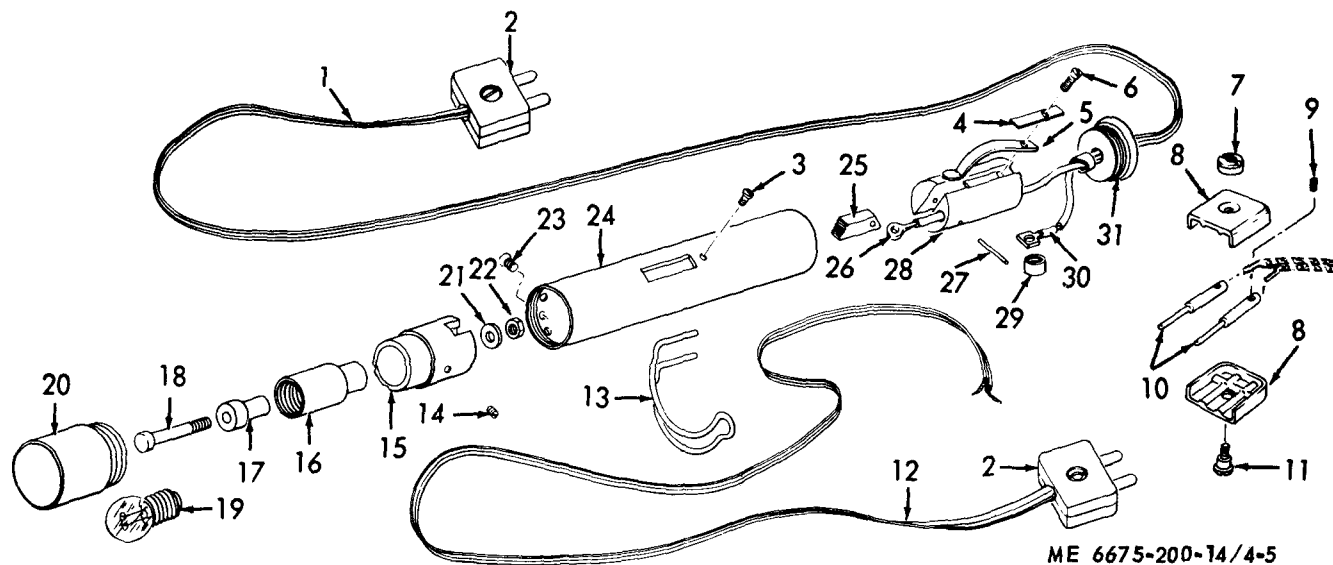

ME 6675-200-14/4-5

- |                             |                             |
|-----------------------------|-----------------------------|
| 1. Cable                    | 17. Insulation tube         |
| 2. Connector plug (3 rqr)   | 18. Lamp contact            |
| 3. Screw (spec)             | 19. Lamp                    |
| 4. Spring                   | 20. Shade tube              |
| 5. Contact spring           | 21. Insulation washer       |
| 6. Screw (spec)             | 22. Nut (spec)              |
| 7. Nut (3 rqr)              | 23. Screw (spec)            |
| 8. Housing (6 rqr)          | 24. Body tube               |
| 9. Screw (spec) (6 rqr)     | 25. Switch lever            |
| 10. Prong (6 rqr)           | 26. Contact terminal sleeve |
| 11. Screw (spec) (3 rqr)    | 27. Pin                     |
| 12. Connector cable         | 28. Switch insulation       |
| 13. Hook ratchet            | 29. Insulator tube          |
| 14. Setscrew (spec) (2 rqr) | 30. Contact sleeve          |
| 15. Lamp insulation         | 31. Cover.                  |
| 16. Lamp housing            |                             |

Figure 4-5. Hand lamp and cable assembly, exploded view.

(2) Remove the screw (3) which holds the switch insulation (28) in place from the body tube (24). Unscrew the cover (31), keeping track of the number of turns required to disengage it from the body tube.

(3) Use a narrow screwdriver to press downward and backward on the switch lever (25) until the switch lever is inside the body tube (24). Reverse the direction of travel of the switch lever and switch insulation (28) carrying the lever, and push the lamp insulation (15) and switch insulation (28) alternately forward far enough to remove the hook ratchet (13) from the body tube (24). Reverse the travel of the lamp insulation (15) and switch insulation (28) and remove them from the rear end of the body tube.

#### NOTE

The two insulations are removed by pushing first one and then the other, progressively, toward and then out of the cover end of the body tube.

(4) Remove the nut (22) and insulation washer (21) from the lamp contact (18). Remove the two setscrews (14) and remove the lamp housing (16) from the lamp insulation (15). Remove the contact (18) and insulation tube (17) from the lamp housing (16). Remove the lamp (19) from the lamp housing.

(5) Remove the screw (6) and lift off the tension spring (4) and contact spring (5). Remove the insulator tube (29) and contact sleeve (30) from the switch insulation (28).

(6) Drive the pin (27) out of the switch insulation (28) and remove the switch lever (25).

(7) Remove the connector plug (2) following the instructions given in paragraph 2-30.

(8) Unsolder the contact sleeve (30) and contact terminal sleeve (26) from the cable (1). Remove the cable (1) from the switch insulation (28). Remove the cover (31) from the cable (1).

(9) Remove the nut (7) and withdraw the screw (11) from the housing (8). Remove the two pieces of housing.

(10) Remove the two screws (9) and separate the connector cable (12) from the two prongs (10).

(11) Disassemble the other connector in the same manner as described above.

*b. Cleaning, Inspection, and Repair.*

(1) Clean all metal parts with an approved cleaning solvent. Wipe the cable clean with a soft cloth. Clean the corrosion from the terminals and contacts. Brush all threaded surfaces free of dirt and all foreign material.

(2) Inspect the tubes and housings for dents, cracks, and breaks. Inspect all insulation for wear and damage. Inspect all contacts for corrosive damage and breaks. Inspect the terminals for burrs, bends, and breaks. Inspect the hook ratchet for bends and damage. Inspect the housings for cracks and breaks.

(3) Repair minor insulation damage to the cable with tape. Straighten out all dents and bends. Remove all burrs with a fine file. Rechase threaded surfaces having minor thread damage or wear. Replace all defective parts that cannot be repaired.

*c. Reassembly.*

(1) Position the bare tips of one end of the cable (1, fig. 4-5) in the mounting holes in two of the prongs (10). Install the two screws (9).

(2) Place the prongs (10) in the housing (8). Position a second housing over the first and install the screw (11) and nut (7).

(3) Assemble the second connector (2) in the same manner as described above.

(4) Place the cover (31) on the cable (1). Position the long end of the cable (1) in the switch insulation (28) and solder the contact sleeve (30) and the contact terminal sleeve (26) to the cable end.

(5) Install the connector plug (2) on the free end of the cable (1) according to the instructions outlined in paragraph 2-30.

(6) Position the contact spring (5) and spring (4) in the slot in the switch insulation (28). Install

the screw (6) in the springs (4 and 5) and the switch insulation (28). Slide the contact sleeve (30) over the end of the screw (6) and install the insulator tube (29) on the screw.

(7) Position the switch lever (25) in the switch insulation (28) and install the pin (27). Insert the lamp contact (18) in the insulation tube (17). Insert the insulation tube in the lamp housing (16) and position the assembly in the lamp insulation (15).

(8) Position the contact terminal sleeve (26) on the lamp contact (18) and secure with the insulation washer (21) and nut (22).

(9) Line up the grooves in the lamp insulation (15) with the mounting holes of the hook ratchet (13) in the body tube (24) and start the lamp insulation into the tube.

(10) Line up the switch lever (25) in the switch insulation (28) with the switch lever opening in the body tube (24). Slide the two assemblies into the tube, moving them progressively until the lamp insulation (15) clears the tube.

(11) Position the ends of the hook ratchet (13) in the mounting holes in the body tube (24). Back up and position the two assemblies in the body tube and secure with the screws (3) and (23).

**CAUTION**

**Be careful not to bend the contact spring (5) when moving the two assemblies backward and forward within the body tube (24).**

(12) Twist the cover (31) backward the number of turns required to engage it in the body tube (24). This will put a reverse twist on the two wires which make up the cable (1). Screw the cover into the tube.

(13) Install a lamp (19) in the lamp housing (16) and install the shade tube (20).

**4-12. Electrical Illumination Assembly**

*a. Disassembly.*

(1) Remove the nut (7, fig. 4-6) and lamp holder (8) from the electrical illumination assembly cover (17).

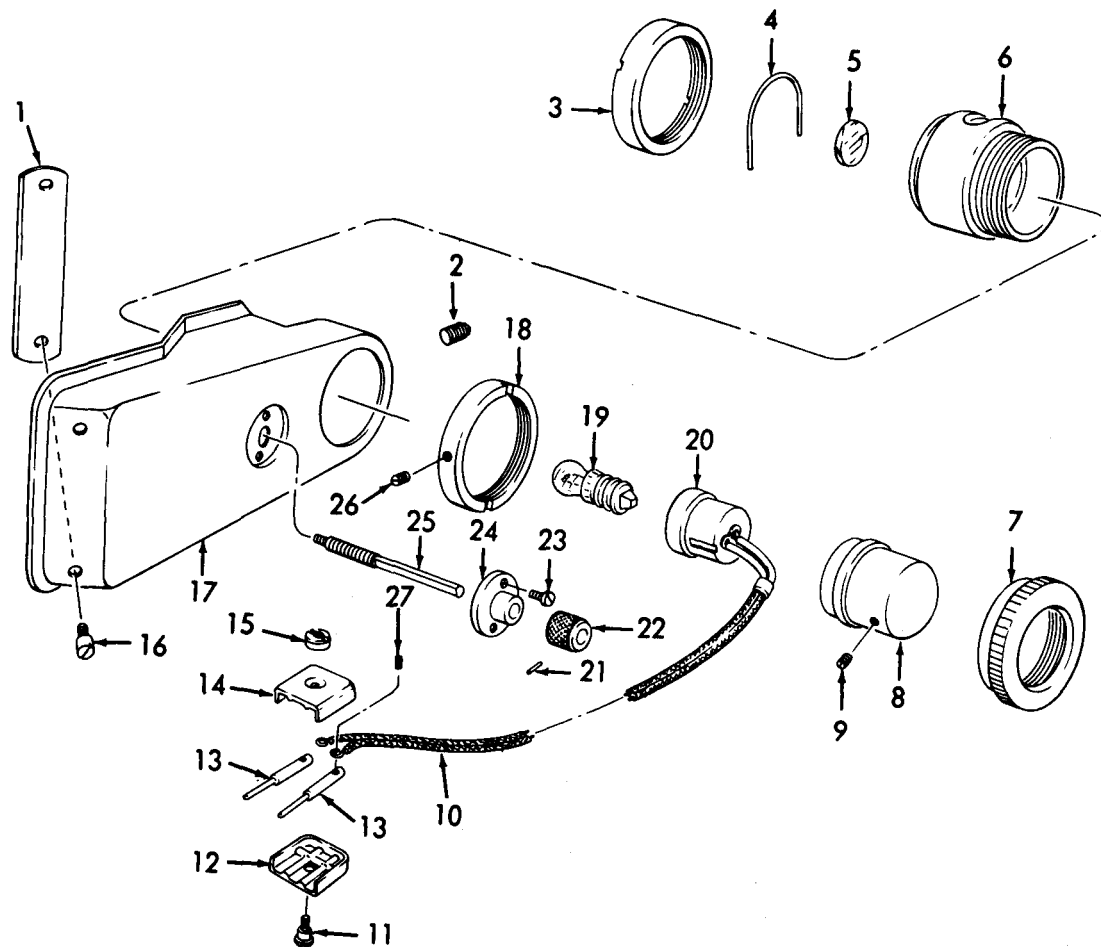

ME 6675-200-14/4-6

- |                              |                                   |
|------------------------------|-----------------------------------|
| 1. Mirror                    | 15. Nut (spec)                    |
| 2. Screw, machine (spec)     | 16. Screw, machine (spec) (2 rqr) |
| 3. Threaded bushing          | 17. Cover                         |
| 4. Retaining clip            | 18. Lockring                      |
| 5. Window                    | 19. Lamp                          |
| 6. Bushing                   | 20. Insulating bushing            |
| 7. Nut (spec)                | 21. Pin (spec)                    |
| 8. Lamp holder               | 22. Knob                          |
| 9. Setscrew (spec)           | 23. Screw, machine (spec)         |
| 10. Cable                    | (2 rqr)                           |
| 11. Screw (spec)             | 24. Sleeve                        |
| 12. Connector housing        | 25. Screw bolt                    |
| 13. Connector' prong (2 rqr) | 26. Setscrew (spec)               |
| 14. Connector housing        | 27. Screw (spec) (2 rqr)          |

Figure 4-6. Electrical illumination assembly, exploded view.

(2) Remove the screw (11) and nut (15) that secure the connector housings (12 and 14) together. Separate and remove the two connector housings.

(3) Remove the two screws (27) that secure the cable (10) to the connector prongs (13) and remove the cable from the connector prongs.

(4) Remove the insulating bushing (20) and cable (10) from the lamp holder (8).

(5) Remove the setscrew (26) that secures the locking ring (18) to the bushing (6) and remove the locking ring from the bushing.

(6) Remove the machine screw (2) from the cover (17) and remove the bushing (6) from the cover.

(7) Remove the pin (21) that secures the knob (22) to the screw bolt (25) and remove the knob from the screw bolt.

(8) Remove the two machine screws (23) that secure the sleeve (24) to the cover (17) and remove the sleeve.

(9) Remove the threaded bushing (3) and retaining clip (4) from the bushing (6) by turning the threaded bushing in a counterclockwise direction.

(10) Break the cement seal and remove the window (5) from the bushing (6).

(11) Remove the two machine screws (16) that secure the mirror (1) to the cover (17) and remove the mirror.

*b. Cleaning, Inspection, and Repair.*

(1) Clean all metal parts with an approved cleaning solvent. Wipe the electrical cable clean with a cloth. Clean and polish the window with lens tissue moistened in grain alcohol or acetone. Brush all threaded surfaces free of dirt and foreign material. Clean the corrosion from the electrical plug contacts.

(2) Inspect the window for cracks or chips. Inspect the lamp holder, light cover, and knob for cracks, breaks, and dents. Inspect the electrical cable insulation for wear or deterioration.

(3) Smooth minor dents. Repair minor insulation damage to the cable with tape. Replace all defective parts that cannot be repaired.

*c. Reassembly.*

(1) Position the mirror (1, fig. 4-6) on the cover (17) and secure with the two machine screws (16).

(2) Position the window (5) in the bushing (6) and cement in place with shellac.

(3) Position the retaining clip (4) on the bushing (6) and secure with the threaded bushing (3) by turning in a clockwise direction.

(4) Position the sleeve (24) on the cover (17) and secure with the two machine screws (23).

(5) Install the screw bolt (25) in the sleeve (24).

(6) Position the knob (22) on the screw bolt (25) and secure with the pin (21).

(7) Position the bushing (6) in the cover (17) and secure with the lockring (18) by turning in a clockwise direction. Secure the lockring with the setscrew (26).

(8) Install the machine screw (2) in the cover (17).

(9) Install the insulating bushing (20) and cable (10) in the lamp holder (8).

(10) Position the lamp holder (8) in the bushing (6) and secure with the nut (7) by turning in a clockwise direction.

(11) Install the cable (10) in the two connector prongs (13) and secure with the two screws (27).

(12) Install the connector prongs (13) in the two halves of the connector housing (12 and 14) and fasten the two halves together with the screw (11) and nut (15).

## APPENDIX A

### REFERENCES

---

**A-1. Fire Protection**

TB 5-4200-200-10

Hand Portable Fire Extinguishers for Army Users.

**A-2. Lubrication**

C91001L

Fuels, Lubricants, Oils and Waxes.

**A-3. Painting**

TM 9-213

Painting Instructions for Field Use.

**A-4. Maintenance**

TM 38-750

TM 5-6675-200-25P

The Army Maintenance Management System.  
Organizational, Direct and General Support and Depot  
Maintenance Repair Parts and Special Tools List, Theodolite  
(Wild Heerbrugg Model T-16).

**A-5. Shipment and Storage**

TM 38-230-1

TM 740-90-1

Preservation and Packing of Military Equipment.  
Administrative Storage of Equipment.

**A-6. Demolition**

TM 750-244-3

Destruction of Materiel to Prevent Enemy Use.



APPENDIX B  
 BASIC ISSUE ITEMS LIST AND ITEMS  
 TROOP INSTALLED OR AUTHORIZED

Section I. INTRODUCTION

**B-1. Scope**

This appendix lists items required by the operator for operation of the theodolite.

**B-2. General**

This list is divided into the following sections:

*a. Basic Issue Items List—Section II.* Not applicable.

*b. Items Troop Installed or Authorized List—Section III.*

A list of items in alphabetical sequence, which at the discretion of the unit commander may accompany the theodolite. These items are NOT SUBJECT TO TURN-IN with the theodolite when evacuated.

**B-3. Explanation of Columns**

The following provides an explanation of columns in the tabular list of Basic Issue Items List, Section II, and Items Troop Installed or Authorized, Section III.

*a. Source, Maintenance, and Recoverability Code(s) (SMR).* Not applicable.

*b. Federal Stock Number.* This column indicates the Federal Stock Number assigned to the item and will be used for requisitioning purposes.

*c. Description.* This column indicates the Federal item name and any additional description of the item required.

*d. Unit of Measure (U/M).* A two character alphabetic abbreviation indicating the amount or quantity of the item upon which the allowances are based, e.g., ft, ea, pr, etc.

*e. Quantity Furnished with Equipment (BIIL).* Not applicable.

*f. Quantity Authorized (Items Troop Installed or Authorized).* This column indicates the quantity of the item authorized to be used with the equipment.

Section III. ITEMS TROOP INSTALLED OR AUTHORIZED LIST

| (1)<br>SMR<br>CODE | (2)<br>FEDERAL<br>STOCK<br>NUMBER | (3)<br>DESCRIPTION                     |                | (4)<br>UNIT<br>OF<br>MEAS. | (5)<br>QTY<br>AUTH |
|--------------------|-----------------------------------|--|----------------|----------------------------|--------------------|
|                    |                                   | REF NO. & MFG CODE                     | USABLE ON CODE |                            |                    |
|                    | 6135-120-1020                     | BATTERY                                |                | E A                        | 4                  |
|                    | 7920-204-0565                     | BRUSH, Dusting                         |                | E A                        | 1                  |
|                    | 7520-559-9618                     | CASE, Maintenance and Operation Manual |                | E A                        | 1                  |
|                    | 8330-965-1722                     | CHAMOIS                                |                | E A                        | 1                  |
|                    | 6675-446-1762                     | CONTAINER, GREASE                      |                | E A                        | 1                  |
|                    | 6675-378-9401                     | COVER, INSTRUMENT                      |                | E A                        | 1                  |
|                    | 6675-353-4123                     | FIELD, PACK, CANVAS                    |                | E A                        | 1                  |
|                    | 6675-859-5936                     | LAMP, INCANDESCENT                     |                | E A                        | 6                  |
|                    | 6675-353-4103                     | PIN, ADJUSTING                         |                | E A                        | 2                  |
|                    | 5120-378-9303                     | SCREWDRIVER                            |                | E A                        | 1                  |
|                    | 5120-446-2860                     | SCREWDRIVER                            |                | E A                        | 1                  |
|                    | 5120-378-9520                     | WRENCH, TRIPOD                         |                | E A                        | 1                  |

# APPENDIX C

## MAINTENANCE ALLOCATION CHART

---

### Section I. INTRODUCTION

#### C-1. General

a. This section provides a general explanation of all maintenance and repair functions authorized at various maintenance levels.

b. Section II designates overall responsibility for the performance of maintenance functions on the identified end item or component and the work measurement time required to perform the functions by the designated maintenance level. The implementation of the maintenance functions upon the end item or component will be consistent with the assigned maintenance functions.

c. Section III lists the special tools and test equipment required for each maintenance function as referenced from Section II.

d. Section IV contains supplemental instructions or explanatory notes for a particular maintenance function.

#### C-2. Explanation of Columns in Section II

a. *Column (1), Group Number.* A number is assigned to each group in a top down breakdown sequence. The applicable groups are listed on the MAC in disassembly sequence beginning with the first group removed.

b. *Column (2), Functional Group.* This column contains a brief description of the components of each numerical group.

c. *Column (3), Maintenance Functions.* This column lists the various maintenance functions (A through K). The lowest maintenance level authorized to perform these functions is indicated by a symbol in the appropriate column. Work measurement time standards (the active repair time required to perform the maintenance function) are shown directly below the symbol identifying the maintenance level. The symbol designations for the various maintenance levels are as follows:

- C . . . Operator or crew
- O . . . Organization maintenance
- F . . . Direct support maintenance
- H . . . General support maintenance
- D . . . Depot maintenance

The maintenance functions are defined as follows:

A— *Inspect:* To determine serviceability of an item by comparing its physical, mechanical, and electrical characteristics with established standards through examination.

B— *Test:* To verify serviceability and detect incipient failure by measuring the mechanical or electrical characteristics of an item and comparing those characteristics with prescribed standards.

C— *Service:* Operations required periodically to keep an item in proper operating condition, i.e., to clean, to preserve, to drain, to paint, or to replenish fuel, lubricants, hydraulic fluids, or compressed air supplies.

D— *Adjust:* To maintain within prescribed limits, by bringing into proper or exact position, or by setting the operating characteristics to specified parameters.

E— *Align:* To adjust specified variable elements of an item to bring about optimum or desired performance.

F— *Calibrate:* To determine and cause corrections to be made or to be adjusted on instruments or test measuring and diagnostic equipments used in precision measurement. Consists of comparisons of two instruments, one of which is a certified standard of known accuracy, to detect and adjust any discrepancy in the accuracy of the instrument being compared.

G— *Install:* The act of emplacing, seating, or fixing into position an item, part, or module (component or assembly) in a manner to allow the proper functioning of an equipment or system.

H— *Replace:* The act of substituting a serviceable like type part, subassembly, or module (component or assembly) for an unserviceable counterpart.

I— *Repair:* The application of maintenance services (inspect, test, service, adjust, align, calibrate, or replace) or other maintenance actions (welding, grinding, riveting, straightening, facing, remachining or resurfacing) to restore serviceability to an item by correcting specific damage, fault, malfunction, or failure in a part, subassembly, module (component or assembly), end item, or system.

J— *Overhaul:* That maintenance effort (service / action) necessary to restore an item to a completely serviceable / operational condition as prescribed by maintenance standards (i.e., DM WR) in appropriate technical publication. Overhaul is normally the highest degree of

maintenance performed by the Army. Overhaul does not normally return an item to like new condition.

K— *Rebuild*: Consists of those services / actions necessary for the restoration of unserviceable equipment of a like new condition in accordance with original manufacturing standards. Rebuild is the highest degree of materiel maintenance applied to Army equipment. The rebuild operation includes the act of returning to zero those age measurement (hours / miles, etc.) considered in classifying Army equipment / components.

d. *Column (4), Tools and Equipment*. This column is provided for referencing by code the special tools and test equipment, (sec III) required to perform the maintenance functions (see II).

e. *Column (5), Remarks*. This column is provided for referencing by code the remarks (see IV) pertinent to the maintenance functions.

### **C-3. Explanation of Columns in Section III**

a. *Reference Code*. This column consists of a number and a letter separated by a dash entered from column 4 on the MAC. The number

references the special tools and test equipment requirements and the letter represents the specific maintenance function the item is to be used with. The letter is representative of columns A through K on the MAC.

b. *Maintenance Category*. This column shows the lowest level of Maintenance authorized to use the special tools or test equipment.

c. *Nomenclature*. This column lists the name or identification of the tools or test equipment.

d. *Tool Number*. This column lists the manufacturer's code and part number, or Federal Stock Number of tools and test equipment.

### **C-4. Explanation of Columns in Section IV**

a. *Reference Code*. This column consists of two letters separated by a dash, entered from column (5), Section II. The first letter references the Remark and the second letter references a maintenance function, column (3), A through K, to which the remark applies.

b. *Remarks*. This column lists information pertinent to the maintenance function being performed, as indicated on the MAC Section II.

Section II. MAINTENANCE ALLOCATION CHART

| (1)<br>Group No. | (2)<br>Functional group   | (3)<br>Maintenance functions |      |         |        |       |           |         |         |        |          |         | (4)<br>Tools and equipment | (5)<br>Remarks |  |     |  |          |
|------------------|---|------------------------------|------|---------|--------|-------|-----------|---------|---------|--------|----------|---------|----------------------------|----------------|--|-----|--|----------|
|                  |   | A                            | B    | C       | D      | E     | F         | G       | H       | I      | J        | K       |                            |                |  |     |  |          |
|                  |   | Inspect                      | Test | Service | Adjust | Align | Calibrate | Install | Replace | Repair | Overhaul | Rebuild |                            |                |  |     |  |          |
| 0101             | 01 Straps, Carrying Case<br>Hood Assembly                         | O                            |      |         |        |       |           |         |         | O      |          |         |                            |                |  |     |  |          |
|                  |   | 0.1                          |      |         |        |       |           |         |         | 0.3    |          |         |                            |                |  |     |  |          |
| 0102             | Case, Field Pack  | O                            |      |         |        |       |           |         |         | O      |          |         |                            |                |  |     |  |          |
|                  |   | 0.1                          |      |         |        |       |           |         |         | 0.5    |          |         |                            |                |  |     |  |          |
|                  | 02 Accessory Items  |                              |      |         |        |       |           |         |         |        |          |         |                            |                |  |     |  |          |
| 0201             | Bag Plastic   | O                            |      |         |        |       |           |         |         | O      |          |         |                            |                |  |     |  |          |
|                  |   | 0.1                          |      |         |        |       |           |         |         | 0.3    |          |         |                            |                |  |     |  |          |
| 0202             | Case Assembly   | O                            |      |         |        |       |           |         |         | O      |          |         |                            |                |  |     |  |          |
|                  |   | 0.1                          |      |         |        |       |           |         |         | 0.5    |          |         |                            |                |  |     |  |          |
|                  | 03 Theodolite   |                              |      |         |        |       |           |         |         |        |          |         |                            |                |  |     |  |          |
| 0301             | Telescope Assembly  |                              |      | O       | O      |       |           |         |         | D      |          |         |                            |                |  | I-D |  | A-C, B-D |
|                  |   |                              |      | 0.1     | 0.3    |       |           |         |         |        |          |         |                            |                |  |     |  |          |
|                  |   |                              |      |         |        |       |           |         |         |        |          |         |                            |                |  |     |  |          |
|                  | 04 Optics   |                              |      |         |        |       |           |         |         |        |          |         |                            |                |  |     |  |          |
| 0401             | Prism Assembly  |                              |      | F       |        |       |           |         |         | D      |          |         |                            |                |  |     |  |          |
|                  |   |                              |      | 0.5     |        |       |           |         |         |        |          |         |                            |                |  |     |  |          |
| 0402             | Prisms: Porro, Viewing,<br>Angle, Degree                          |                              |      | F       | O      |       |           |         |         | D      |          |         |                            |                |  |     |  |          |
|                  |   |                              |      | 0.5     | 0.5    |       |           |         |         | 2.0    |          |         |                            |                |  |     |  |          |
| 0403             | Mirror Assembly,<br>Illumination                                  |                              |      | O       |        |       |           |         |         | O      | F        |         |                            |                |  |     |  |          |
|                  |   |                              |      | 0.1     |        |       |           |         |         | 0.1    | 0.1      |         |                            |                |  |     |  |          |
| 0404             | Circle, Vertical, Degree<br>and MIL                               | D                            |      |         |        |       |           |         |         | D      |          |         |                            |                |  |     |  |          |
|                  |   | 0.1                          |      |         |        |       |           |         |         | 3.0    |          |         |                            |                |  |     |  |          |
| 0405             | Readout Assembly  | O                            |      |         | D      |       |           |         |         | D      |          |         |                            |                |  |     |  | C-A      |
|                  |   | 0.1                          |      |         | 0.5    |       |           |         |         | 2.0    |          |         |                            |                |  |     |  |          |
| 0406             | Illumination Assembly<br>Horizontal & Vertical                    | D                            |      |         |        |       |           |         |         | O      | D        |         |                            |                |  |     |  |          |
|                  |   | 0.1                          |      |         |        |       |           |         |         | 0.4    | 1.3      |         |                            |                |  |     |  |          |
| 0407             | Mount Illumination  | D                            |      |         |        |       |           |         |         | D      |          |         |                            |                |  |     |  |          |
|                  |   | 0.1                          |      |         |        |       |           |         |         | 1.0    |          |         |                            |                |  |     |  |          |
| 0408             | Lens & Mount Assembly   | D                            |      |         |        |       |           |         |         | D      |          |         |                            |                |  |     |  |          |
|                  |   | 0.1                          |      |         |        |       |           |         |         | 4.0    |          |         |                            |                |  |     |  |          |
| 0409             | Microscope Assembly<br>Lens, eye, field,<br>objective & Condensor |                              |      | O       | O      |       |           |         |         | D      |          |         |                            |                |  |     |  | D-C, E-D |
|                  |   |                              |      | 0.1     | 0.2    |       |           |         |         | 1.5    |          |         |                            |                |  |     |  |          |
| 0410             | Eyepiece: Right Angle<br>T & Reticle                              |                              |      | O       |        |       |           |         |         | O      |          |         |                            |                |  |     |  | F-C      |
|                  |   |                              |      | 0.1     |        |       |           |         |         | 1.4    |          |         |                            |                |  |     |  |          |
| 0411             | Eyepiece: Optical<br>Plumb & Compass                              |                              |      | O       |        |       |           |         |         | O      |          |         |                            |                |  |     |  |          |
|                  |   |                              |      | 0.1     |        |       |           |         |         | 0.3    |          |         |                            |                |  |     |  |          |
| 0412             | Filters   |                              |      | O       |        |       |           |         |         | O      |          |         |                            |                |  |     |  |          |
|                  |   |                              |      | 0.1     |        |       |           |         |         | 0.1    |          |         |                            |                |  |     |  |          |
| 0413             | Reticle Assembly,<br>Illumination                                 |                              |      | O       |        |       |           |         |         |        | D        |         |                            |                |  |     |  | G-C      |
|                  |   |                              |      | 0.2     |        |       |           |         |         |        | 4.0      |         |                            |                |  |     |  |          |
|                  | 05 Mechanical, Structural, and Precision Parts                    |                              |      |         |        |       |           |         |         |        |          |         |                            |                |  |     |  |          |
| 501              | Base Assembly, Azimuth  |                              |      | O       |        |       |           |         |         | D      |          |         |                            |                |  |     |  | H-C      |
|                  |   |                              |      | 0.1     |        |       |           |         |         |        | 3.5      |         |                            |                |  |     |  |          |
| 502              | Housing Assembly, Azimuth<br>Base                                 |                              |      |         | D      |       |           |         |         | D      |          |         |                            |                |  |     |  |          |
|                  |   |                              |      |         | 1.0    |       |           |         |         |        | 1.5      |         |                            |                |  |     |  |          |
| 503              | Screw Assembly, Tangent<br>& Clamp                                |                              |      | O       |        |       |           |         |         | D      |          |         |                            |                |  |     |  | I-C      |
|                  |   |                              |      | 0.5     |        |       |           |         |         | 1.0    |          |         |                            |                |  |     |  |          |
| 504              | Base Assembly, Inner  | D                            |      |         |        |       |           |         |         |        | D        |         |                            |                |  |     |  |          |
|                  |   | 0.1                          |      |         |        |       |           |         |         |        | 3.5      |         |                            |                |  |     |  |          |
| 505              | Clamp Assembly, repeating   |                              |      |         | D      |       |           |         |         | D      |          |         |                            |                |  |     |  |          |
|                  |   |                              |      |         | 0.2    |       |           |         |         |        | 0.5      |         |                            |                |  |     |  |          |
| 506              | Standard Assembly   |                              |      | O       |        |       |           |         |         | D      |          |         |                            |                |  |     |  | J-C      |
|                  |   |                              |      | 0.5     |        |       |           |         |         |        | 0.5      |         |                            |                |  |     |  |          |
| 507              | Spindle Assembly  | D                            |      |         |        |       |           |         |         | D      |          |         |                            |                |  |     |  |          |
|                  |   | 0.1                          |      |         |        |       |           |         |         | 2.0    |          |         |                            |                |  |     |  |          |
| 508              | Bearing Shell Assy  |                              |      | D       |        |       |           |         |         | D      |          |         |                            |                |  |     |  |          |
|                  |   |                              |      | 0.5     |        |       |           |         |         | 2.0    |          |         |                            |                |  |     |  |          |

Section II. MAINTENANCE ALLOCATION CHART

| Group No. | (2)<br>Functional group   | (3)<br>Maintenance functions |      |          |          |       |           |          |          |        |          | (4)<br>Tools and equipment | (5)<br>Remarks |          |  |     |
|-----------|---|------------------------------|------|----------|----------|-------|-----------|----------|----------|--------|----------|----------------------------|----------------|----------|--|-----|
|           |   | A                            | B    | C        | D        | E     | F         | G        | H        | I      | J        |                            |                | K        |  |     |
|           |   | Inspect                      | Test | Service  | Adjust   | Align | Calibrate | Install  | Replace  | Repair | Overhaul |                            |                | Rebuild  |  |     |
| 0509      | 05 Eyepiece Assembly  |                              |      | O<br>0.1 |          |       |           |          | D<br>0.6 |        |          |                            |                |          |  | K-C |
| 0510      | 05 Reflector, Bearing,<br>Mounts                                    | D<br>0.1                     |      |          |          |       |           | D<br>2.0 |          |        |          |                            |                |          |  |     |
| 0511      | 05 Housing, sights  |                              |      |          | D<br>1.0 |       |           | D<br>4.0 |          |        |          |                            |                |          |  |     |
| 0512      | 05 Box Assembly, Battery  |                              |      |          |          |       |           | O<br>0.1 | F<br>2.0 |        |          |                            |                |          |  |     |
| 0513      | 05 Light, Hand  | O<br>0.1                     |      |          |          |       |           | O<br>0.2 | F<br>0.3 |        |          |                            |                |          |  |     |
| 0514      | 05 Circuits, Components   | O<br>0.1                     |      |          |          |       |           | F<br>0.5 |          |        |          |                            |                |          |  | L-A |
| 0515      | 05 Mounted Connecting<br>Devices                                    | O<br>0.1                     |      |          |          |       |           | D<br>1.0 |          |        |          |                            |                |          |  |     |
| 0601      | 06 Miscellaneous Wiring and Fittings<br>Cord Assembly,<br>Extension | O<br>0.1                     |      |          |          |       |           | O<br>0.1 |          |        |          |                            |                |          |  |     |
| 0602      | 06 Illumination Assembly  | O<br>0.1                     |      |          |          |       |           | O<br>0.2 | F<br>0.2 |        |          |                            |                |          |  |     |
| 0603      | 06 Wire, Hook-up, Internal  | D<br>1.0                     |      |          |          |       |           | D<br>1.5 |          |        |          |                            |                |          |  |     |
| 0604      | 06 Plug Assembly, Battery<br>Box                                    | O<br>0.1                     |      |          |          |       |           | F<br>0.3 |          |        |          |                            |                |          |  |     |
| 0701      | 07 Compass & Level<br>Compass Assembly                              |                              |      | O<br>1.0 |          |       |           | O<br>0.1 | H<br>3.0 |        |          |                            |                |          |  | M-C |
| 0702      | 07 Level Assemblies, Circular<br>and Altitude                       |                              |      | D<br>0.1 | O<br>0.1 |       |           | F<br>0.2 | D<br>1.5 |        |          |                            |                | 2-D, 3-D |  |     |
| 0703      | 07 Vial Assembly, Telescope<br>Level                                |                              |      | O<br>1.5 | O<br>1.5 |       |           | F<br>1.5 | D<br>1.5 |        |          |                            |                |          |  |     |
| 0704      | 07 Retainers: Housing,<br>springs                                   | O<br>0.5                     |      |          |          |       |           | D<br>3.5 |          |        |          |                            |                |          |  |     |
| 0801      | 08 Tripods  |                              |      | O<br>0.1 | O        |       |           | O<br>0.1 | O<br>2.0 |        |          |                            |                | 4-I      |  |     |

Section III. SPECIAL TOOL AND SPECIAL TEST EQUIPMENT REQUIREMENTS

| Reference code | Maintenance Category | Nomenclature   | Tool number   |
|----------------|----------------------|----------------|---------------|
| 1              | 0                    | Pin, Adjusting | 6675-353-4103 |
| 2              | 0                    | Screwdriver    | 5120-429-2940 |
| 3              | 0                    | Screwdriver    | 5120-446-2860 |
| 4              | 0                    | Wrench, Tripod | 5120-378-9520 |

Section IV. REMARKS

| Reference Code | Remarks  |
|----------------|----------|
| A-C            | External |
| B-D            | External |
| C-A            | External |
| D-C            | External |
| E-D            | External |
| F-C            | External |
| G-C            | External |
| H-C            | External |
| I-C            | External |
| J-C            | External |
| K-C            | Clean    |
| L-A            | External |
| M-C            | External |

# INDEX

|   | Paragraph | Page     |   | Paragraph | Page     |
|---|-----------|----------|---|-----------|----------|
| <b>A</b>                                    |           |          | <b>C</b>                                    |           |          |
| Accessory case and accessories . . . . .    | 3-43      | 3-19     | Controls and instruments:                   |           |          |
| Adjustments:                                |           |          | Circular level . . . . .                    | 2-22      | 2-4      |
| Circular compass . . . . .                  | 2-26      | 2-8      | Collimation level mirror                    |           |          |
| Circular level . . . . .                    | 2-26      | 2-8      | assembly . . . . .                          | 2-24      | 2-5      |
| Foot screws . . . . .                       | 2-26      | 2-8      | Collimation slow motion screw . . . . .     | 2-15      | 2-3      |
| Horizontal slow motion screw . . . . .      | 2-26      | 2-8      | Compass caging knob . . . . .               | 2-8       | 2-1      |
| Optical plumb . . . . .                     | 2-26      | 2-8      | Compass clamp screw . . . . .               | 2-9       | 2-1      |
| Plate level . . . . .                       | 2-26      | 2-8      | Compass eyepiece . . . . .                  | 2-10      | 2-1      |
| Tripod . . . . .                            | 2-26      | 2-8      | Compass holder . . . . .                    | 2-7       | 2-1      |
| Vertical collimation level                  |           |          | Compass index ring . . . . .                | 2-11      | 2-1      |
| assembly . . . . .                          | 4-5       | 4-2      | Foot screws . . . . .                       | 2-17      | 2-3      |
| Vertical collimation level                  |           |          | Horizontal circle scale . . . . .           | 2-21      | 2-4      |
| mirror . . . . .                            | 2-26      | 2-8      | Horizontal clamp screw . . . . .            | 2-16      | 2-3      |
| Vertical collimation slow                   |           |          | Horizontal slow motion screw . . . . .      | 2-14      | 2-3      |
| motion screw . . . . .                      | 2-26      | 2-8      | Microscope assembly . . . . .               | 2-6       | 2-1      |
| Vertical slow motion                        |           |          | Optical plumb . . . . .                     | 2-19      | 2-3      |
| screw . . . . .                             | 2-26      | 2-8      | Plate level . . . . .                       | 2-23      | 2-4      |
| Administrative storage . . . . .            | 1-6       | 1-1      | Reticle mirror knob . . . . .               | 2-3       | 2-1      |
| Alidade and optical plumb assembly:         |           |          | Telescope eyepiece . . . . .                | 2-5       | 2-1      |
| Alidade . . . . .                           | 3-36      | 3-18     | Telescope focusing ring . . . . .           | 2-4       | 2-1      |
| Optical plumb assembly . . . . .            | 3-37      | 3-19     | Tribrach clamp lever . . . . .              | 2-18      | 2-3      |
| <b>B</b>                                    |           |          | Vertical circle scale . . . . .             | 2-20      | 2-3      |
| Base assembly . . . . .                     | 3-14      | 3-9      | Vertical clamp screw . . . . .              | 2-2       | 2-1      |
| Battery box assembly . . . . .              | 3-41      | 3-19     | Vertical slow motion screw . . . . .        | 2-12      | 2-3      |
| <b>C</b>                                    |           |          | Conversion, equipment . . . . .             | 2-28      | 2-11     |
| Cable . . . . .                             | 4-11      | 4-8      | <b>D</b>                                    |           |          |
| Canvas field pack . . . . .                 | 3-16      | 3-12     | Data, tabulated . . . . .                   | 1-9       | 1-7      |
| Carrying assembly . . . . .                 | 3-14      | 3-9      | Daytime operation . . . . .                 | 2-26      | 2-8      |
| Carrying cases:                             |           |          | Description . . . . .                       | 1-7       | 1-1      |
| Canvas field pack . . . . .                 | 3-16      | 3-12     | Desiccant container . . . . .               | 3-15      | 3-11     |
| Metal hood assembly . . . . .               | 3-14      | 3-9      | Destruction of army materiel . . . . .      | 1-5       | 1-1      |
| Circular level . . . . .                    | 2-22      | 2-4      | Diagonal eyepiece . . . . .                 | 3-19      | 3-13     |
| Circular level bubble does                  |           |          | Differences in models . . . . .             | 1-8       | 1-1      |
| not stay in center . . . . .                | 3-13      | 3-8      | Dimensions and weights . . . . .            | 1-9       | 1-1      |
| Circular and plate levels . . . . .         | 3-34      | 3-18     | Dismantling . . . . .                       | 2-26      | 2-8      |
| Clamp lever, tribrach . . . . .             | 2-18      | 2-3      | Dusty or sandy area operation . . . . .     | 2-34      | 2-15     |
| Cold weather operation . . . . .            | 2-32      | 2-14     | <b>E</b>                                    |           |          |
| Collimation level bubble does               |           |          | Electrical illumination assembly . . . . .  | 2-29      | 2-11     |
| not stay in center . . . . .                | 3-13,4-5  | 3-8,4-2  | Equipment conversion . . . . .              | 2-28      | 2-11     |
| collimation level mirror assembly . . . . . | 2-24,3-25 | 2-5,3-14 | Equipment serviceability criteria . . . . . | 1-4       | 1-1      |
| Collimation slow motion                     |           |          | Errors, reporting . . . . .                 | 1-3       | 1-1      |
| screw assembly . . . . .                    | 2-15      | 2-3      | Eyepieces:                                  |           |          |
| Compass assembly . . . . .                  | 3-32      | 3-18     | Compass . . . . .                           | 2-10      | 2-1      |
| Compass assembly will not seat              |           |          | Diagonal . . . . .                          | 3-19      | 3-13     |
| properly on compass . . . . .               | 4-5       | 4-2      | Microscope . . . . .                        | 3-18      | 3-12     |
| Compass assembly will not                   |           |          | Optical plumb . . . . .                     | 3-18      | 3-12     |
| seat properly on theodolite                 |           |          | Sunglasses . . . . .                        | 3-20      | 3-13     |
| mounting yoke . . . . .                     | 3-13      | 3-8      | Telescope . . . . .                         | 2-5,3-18  | 2-13,12  |
| Compass caging knob . . . . .               | 2-8       | 2-1      | <b>F</b>                                    |           |          |
| Compass clamp screw . . . . .               | 2-9       | 2-1      | Field pack . . . . .                        | 3-16      | 3-12     |
| Compass circle will not                     |           |          | Focusing ring, telescope . . . . .          | 2-4       | 2-1      |
| rotate freely . . . . .                     | 3-13      | 3-8      | Foot screws . . . . .                       | 2-17,3-22 | 2-3,3-13 |
| Compass eyepiece . . . . .                  | 2-10,3-32 | 2-1,3-18 | Foot screws too tight                       |           |          |
| Compass holder . . . . .                    | 2-7       | 2-1      | or too loose . . . . .                      | 3-13,4-5  | 3-8,4-2  |
| Compass housing will not                    |           |          | Forms, record and report . . . . .          | 1-2       | 1-1      |
| rotate on compass base . . . . .            | 3-13      | 3-8      |   |           |          |
| Compass index ring . . . . .                | 2-11      | 2-1      |   |           |          |
| Compass needle screw . . . . .              | 3-31      | 3-17     |   |           |          |

|  | Paragraph | Page      |
|--|-----------|-----------|
| <b>H</b>   |           |           |
| Hand lamp assembly . . . . .   | 3-39      | 3-19      |
| Hand lamp, plug-in lamp,<br>and battery box assemblies:                  |           |           |
| Battery box assembly . . . . .   | 3-41      | 3-19      |
| Hand lamp assembly . . . . .   | 3-39,4-1  | 13-19,4-8 |
| Plug-in lamp assembly. . . . .   | 3-40      | 3-19      |
| Holder, compass . . . . .  | 2-7       | 2-1       |
| Hood assembly, metal . . . . .   | 3-14      | 3-9       |
| Horizontal circle clamp assembly. . . . .                                | 2-14      | 2-3       |
| Horizontal circle movement trouble. . . . .                              | 3-13      | 3-8       |
| Horizontal circle scale . . . . .  | 2-21      | 2-4       |
| Horizontal clamp screw . . . . .   | 2-16      | 2-3       |
| Horizontal slow motion screw . . . . .                                   | 2-13      | 2-3       |
| Hot weather operation . . . . .  | 2-33      | 2-14      |
| Housing, vertical collimation. . . . .                                   | 4-5       | 4-2       |
| <b>I</b>   |           |           |
| Identification. . . . .  | 1-7       | 1-1       |
| Illumination assembly, electrical . . . . .                              | 2-29      | 2-11      |
| Illumination mirror assembly . . . . .                                   | 3-24      | 3-13      |
| Illumination system:   |           |           |
| Battery box . . . . .  | 4-10      | 4-6       |
| Electrical illumination<br>assembly . . . . .                            | 4-12      | 4-10      |
| Hard lamp and cable . . . . .  | 4-11      | 4-8       |
| Mirror . . . . .   | 4-8       | 4-4       |
| Inspection of new equipment . . . . .                                    | 3-2       | 3-4       |
| Installation . . . . .   | 2-25      | 2-5       |
| Instrument will not stay on line . . . . .                               | 3-13      | 3-8       |
| <b>K</b>   |           |           |
| Knob, compass caging . . . . .   | 2-8       | 2-1       |
| Knob, reticle mirror . . . . .   | 2-3       | 2-1       |
| <b>L</b>   |           |           |
| Lamp assembly, hand . . . . .  | 3-39      | 3-19      |
| Lamp assembly, plug-in . . . . .   | 3-40      | 3-19      |
| Lenses dirty, tarnished, fogged,<br>or etched . . . . .                  | 3-13      | 3-8       |
| Level assembly, plate . . . . .  | 4-6       | 4-3       |
| Level, circular . . . . .  | 2-22      | 2-4       |
| Level plate . . . . .  | 2-23      | 2-4       |
| Lever assemblies, vertical<br>collimation . . . . .                      | 4-5       | 4-2       |
| Lever, tribrach clamp . . . . .  | 2-18      | 2-3       |
| Lighting system faulty or<br>fails to function. . . . .                  | 3-13,4-5  | 3-8,4-2   |
| Lights on vertical and horizontal<br>circles unequal or absent . . . . . | 3-13      | 3-8       |
| Lubrication:   |           |           |
| Detailed information . . . . .   | 3-9       | 3-6       |
| General information. . . . .   | 3-8       | 3-6       |
| Lubricants . . . . .   | 3-9       | 3-6       |
| <b>M</b>   |           |           |
| Maintenance forms and records . . . . .                                  | 1-2       | 1-1       |
| Maintenance, organizational . . . . .                                    | 3-14      | 3-9       |
| Metal hood assembly . . . . .  | 3-14      | 3-9       |
| Microscope assembly . . . . .  | 2-6       | 2-1       |
| Microscope eyepiece . . . . .  | 3-18      | 3-12      |
| Mirror assemblies:   |           |           |
| Collimation level. . . . .   | 2-24,3-25 | 2-5,3-14  |
| Illumination . . . . .   | 3-24      | 3-13      |
| Models, differences in . . . . .   | 1-8       | 1-1       |
| Movement to new work site . . . . .                                      | 2-27      | 2-11      |
| <b>N</b>   |           |           |
| Nighttime operation . . . . .  | 2-26      | 2-8       |

|  | Paragraph | Page     |
|--|-----------|----------|
| <b>O</b>   |           |          |
| Operating details . . . . .                                      | 2-26      | 2-8      |
| Operation under unusual conditions:                              |           |          |
| Dusty or sandy areas . . . . .                                   | 2-34      | 2-15     |
| Extreme cold . . . . .   | 2-32      | 2-14     |
| Extreme heat . . . . .   | 2-33      | 2-14     |
| Rainy or humid conditions . . . . .                              | 2-35      | 2-15     |
| Salt water areas . . . . .                                       | 2-36      | 2-15     |
| Operation under unusual condition . . . . .                      | 2-26      | 2-8      |
| Optical plumb assembly . . . . .                                 | 2-19,3-27 | 2-3,3-14 |
| <b>P</b>   |           |          |
| Plate level assembly . . . . .                                   | 2-23,4-6  | 2-4,4-3  |
| Plate level bubble does not<br>stay in center . . . . .          | 3-13,4-5  | 3-8,4-2  |
| Plug-in lamp assembly . . . . .                                  | 3-40      | 3-19     |
| Plumb bob . . . . .  | 3-29      | 3-16     |
| Plumb, optical . . . . .   | 2-19      | 2-3      |
| <b>R</b>   |           |          |
| Rainy or humid weather<br>operation . . . . .                    | 2-35      | 2-15     |
| Record and report forms . . . . .                                | 1-2       | 1-1      |
| Reference mark not clearly visible . . . . .                     | 3-13      | 3-8      |
| Reference marks not clearly<br>visible or out of focus . . . . . | 4-5       | 4-2      |
| Reporting of errors . . . . .                                    | 1-3       | 1-1      |
| Reticle mirror knob . . . . .                                    | 2-3       | 2-1      |
| Ring, compass index . . . . .                                    | 2-11      | 2-1      |
| Ring, telescope focusing. . . . .                                | 2-4       | 2-1      |
| <b>S</b>   |           |          |
| Salt water area operation . . . . .                              | 2-36      | 2-15     |
| Scale, horizontal circle . . . . .                               | 2-21      | 2-4      |
| Scale, vertical circle . . . . .                                 | 2-20      | 2-3      |
| Scope . . . . .  | 1-1       | 1-1      |
| Screws:  |           |          |
| Collimation slow motion. . . . .                                 | 2-15      | 2-3      |
| Compass clamp. . . . .   | 2-9       | 2-1      |
| Foot . . . . .   | 2-17      | 2-3      |
| Horizontal clamp . . . . .                                       | 2-16      | 2-3      |
| Horizontal slow motion. . . . .                                  | 2-15      | 2-3      |
| Vertical clamp . . . . .   | 2-2       | 2-1      |
| Vertical slow motion . . . . .                                   | 2-12      | 2-3      |
| Service upon receipt of equipment:                               |           |          |
| Equipment conversion. . . . .                                    | 2-28      | 2-11     |
| Inspection of new equipment . . . . .                            | 3-2       | 3-4      |
| Installation or setting-up<br>instructions . . . . .             | 2-25      | 2-12     |
| Servicing new equipment. . . . .                                 | 3-3       | 3-5      |
| Unpacking new equipment . . . . .                                | 3-1       | 3-1      |
| Used equipment . . . . .   | 3-4       | 3-5      |
| Slow motion screw:   |           |          |
| Collimation . . . . .  | 2-15      | 2-3      |
| Horizontal . . . . .   | 2-14      | 2-3      |
| Vertical . . . . .   | 2-12      | 2-3      |
| Special tools and equipment:                                     |           |          |
| Specially designed tools<br>and equipment . . . . .              | 4-3       | 4-1      |
| Special tools and equipment . . . . .                            | 3-6,4-1   | 3-5,4-1  |
| Star plate assembly. . . . .                                     | 3-22      | 3-13     |
| Storage, administrative . . . . .                                | 1-6       | 1-1      |
| Sunglasses . . . . .   | 3-20      | 3-13     |
| <b>T</b>   |           |          |
| Tabulated data . . . . .   | 1-9       | 1-7      |
| Telescope eyepiece . . . . .                                     | 2-5       | 2-1      |
| Telescope focusing ring . . . . .                                | 2-4       | 2-1      |



|                                    | Paragraph | Page |
|------------------------------------|-----------|------|
| <b>T</b>                           |           |      |
| Theodolite will not seat properly  |           |      |
| on tripod head . . . . .           | 3-13      | 3-8  |
| Tools and equipment:               |           |      |
| Direct support and general         |           |      |
| support . . . . .                  | 4-1,4-3   | 4-1  |
| Organizational . . . . .           | 3-5,3-6   | 3-5  |
| Tribrach . . . . .                 | 3-22      | 3-13 |
| Tribrach clamp lever . . . . .     | 2-18      | 2-3  |
| Tribrach, foot screw, and          |           |      |
| star plate assemblies . . . . .    | 3-22      | 3-13 |
| Tripod assembly . . . . .          | 3-27      | 3-13 |
| Tripod leg play excessive. . . . . | 3-13      | 3-8  |
| Tripod legs will not               |           |      |
| lock in position . . . . .         | 3-13      | 3-8  |
| Tripod and tripod accessory case:  |           |      |
| Tripod . . . . .                   | 3-27      | 3-13 |
| Tripod accessory case . . . . .    | 3-28      | 3-13 |
| Tripod wrench . . . . .            | 3-30      | 3-13 |

|                                     | Paragraph | Page |
|-------------------------------------|-----------|------|
| <b>T</b>                            |           |      |
| Troubleshooting:                    |           |      |
| Direct support and                  |           |      |
| general support . . . . .           | 4-5       | 4-2  |
| Organizational . . . . .            | 3-13      | 3-8  |
| <b>U</b>                            |           |      |
| Unpacking new equipment . . . . .   | 3-1       | 3-1  |
| Used equipment. . . . .             | 3-4       | 3-5  |
| <b>V</b>                            |           |      |
| Vertical circle scale. . . . .      | 2-20      | 2-3  |
| Vertical collimation level          |           |      |
| assembly. . . . .                   | 4-5       | 4-2  |
| Vertical slow motion screw. . . . . | 2-12      | 2-3  |
| <b>W</b>                            |           |      |
| Weights. . . . .                    | 1-9       | 1-1  |
| Wrench, tripod . . . . .            | 3-30      | 3-17 |

By Order of the Secretary of the Army:

CREIGHTON W. ABRAMS  
*General, United States Army*  
*Chief of Staff*

Official:

VERNE L. BOWERS  
*Major General, United States Army*  
*The Adjutant General*

Distribution:

To be distributed in accordance with DA Form 12-25A (qty rqr block No. 173)  
operator's maintenance requirements for Surveying Equipment.



# SOMETHING WRONG WITH THIS MANUAL?

THEN... JOT DOWN THE DOPE ABOUT IT ON THIS FORM, TEAR IT OUT, FOLD IT AND DROP IT IN THE MAIL!

FROM: (YOUR UNIT'S COMPLETE ADDRESS)  
 PFC JOHN DOE  
 CoA, 3<sup>rd</sup> ENGINEER BN  
 FT. LEONARD WOOD MO 63108  
 DATE 6 JAN 78

PUBLICATION NUMBER: TM 5-6675-200-14  
 DATE: 31 MAY 73  
 TITLE: THEODOLITE: DIRECTIONAL  
 NSN 6675-00-052-1683

BE EXACT... PIN-POINT WHERE IT IS

IN THIS SPACE TELL WHAT IS WRONG AND WHAT SHOULD BE DONE ABOUT IT:

| PAGE NO. | PARA-GRAPH | FIGURE NO. | TABLE NO. |
|----------|------------|------------|-----------|
| 6        | 2-1<br>a   |            |           |
| 81       |            | 4-3        |           |
| 125      | line 20    |            |           |

In line 6 of paragraph 2-1a the manual states the engine has 6 cylinders. The engine on my set only has 4 cylinders. Change the manual to show 4 cylinders.

Callout 16 on figure 4-3 is pointing at a bolt. In the key to fig. 4-3, item 16 is called a shim. Please correct one or the other.

I ordered a gasket, item 19 on figure B-16 by NSN 2910-00-762-3001. I got a gasket but it doesn't fit. Supply says I got what I ordered so the NSN is wrong. Please give me a good NSN.

TYPED NAME, GRADE OR TITLE, AND TELEPHONE NUMBER: JOHN DOE, PFC (268) 317-7111  
 SIGN HERE: John Doe

FORM 2028-2 (TEST) 1 AUG 74

P.S.--IF YOUR OUTFIT WANTS TO KNOW ABOUT YOUR MANUAL "FIND," MAKE, A CARBON COPY OF THIS AND GIVE IT TO YOUR HEADQUARTERS.

TEAR ALONG DOTTED LINE

RECOMMENDED CHANGES TO EQUIPMENT TECHNICAL MANUALS



# SOMETHING WRONG WITH THIS MANUAL?

THEN... JOT DOWN THE DOPE ABOUT IT ON THIS FORM, TEAR IT OUT, FOLD IT AND DROP IT IN THE MAIL!

FROM: (YOUR UNIT'S COMPLETE ADDRESS)

DATE

PUBLICATION NUMBER

TM 5-6675-200-14

DATE

31 MAY 1973

TITLE

THEODOLITE: DIRECTIONAL  
NSN 6675-00-052-1683

BE EXACT... PIN-POINT WHERE IT IS

IN THIS SPACE TELL WHAT IS WRONG AND WHAT SHOULD BE DONE ABOUT IT:

PAGE NO.

PARA-GRAPH

FIGURE NO.

TABLE NO.

TEAR ALONG DOTTED LINE

TYPED NAME, GRADE OR TITLE, AND TELEPHONE NUMBER

SIGN HERE:

FILL IN YOUR  
UNIT'S ADDRESS



FOLD BACK

---

**DEPARTMENT OF THE ARMY**

---

**OFFICIAL BUSINESS**

Commander  
US Army Troop Support and Aviation  
Materiel Readiness Command  
ATTN: DRSTS-MTPS  
4300 Goodfellow Boulevard  
St. Louis, MO 63120

---

FOLD BACK

# THE METRIC SYSTEM AND EQUIVALENTS

## WEIGHT MEASURE

1 Centimeter = 10 Millimeters = 0.01 Meters = 0.3937 Inches  
 1 Meter = 100 Centimeters = 1000 Millimeters = 39.37 Inches  
 1 Kilometer = 1000 Meters = 0.621 Miles

## WEIGHTS

1 Gram = 0.001 Kilograms = 1000 Milligrams = 0.035 Ounces  
 1 Kilogram = 1000 Grams = 2.2 lb.  
 1 Metric Ton = 1000 Kilograms = 1 Megagram = 1.1 Short Tons

## LIQUID MEASURE

1 Milliliter = 0.001 Liters = 0.0338 Fluid Ounces  
 1 Liter = 1000 Milliliters = 33.82 Fluid Ounces

## SQUARE MEASURE

1 Sq. Centimeter = 100 Sq. Millimeters = 0.155 Sq. Inches  
 1 Sq. Meter = 10,000 Sq. Centimeters = 10.76 Sq. Feet  
 1 Sq. Kilometer = 1,000,000 Sq. Meters = 0.386 Sq. Miles

## CUBIC MEASURE

1 Cu. Centimeter = 1000 Cu. Millimeters = 0.06 Cu. Inches  
 1 Cu. Meter = 1,000,000 Cu. Centimeters = 35.31 Cu. Feet

## TEMPERATURE

$5/9(^{\circ}\text{F} - 32) = ^{\circ}\text{C}$   
 212° Fahrenheit is equivalent to 100° Celsius  
 90° Fahrenheit is equivalent to 32.2° Celsius  
 32° Fahrenheit is equivalent to 0° Celsius  
 $9/5^{\circ}\text{C} + 32 = ^{\circ}\text{F}$

## APPROXIMATE CONVERSION FACTORS

| TO CHANGE              | TO                   | MULTIPLY BY |
|------------------------|----------------------|-------------|
| Inches                 | Centimeters          | 2.540       |
| Feet                   | Meters               | 0.305       |
| Yards                  | Meters               | 0.914       |
| Miles                  | Kilometers           | 1.609       |
| Square Inches          | Square Centimeters   | 6.451       |
| Square Feet            | Square Meters        | 0.093       |
| Square Yards           | Square Meters        | 0.836       |
| Square Miles           | Square Kilometers    | 2.590       |
| Acres                  | Square Hectometers   | 0.405       |
| Cubic Feet             | Cubic Meters         | 0.028       |
| Cubic Yards            | Cubic Meters         | 0.765       |
| Fluid Ounces           | Milliliters          | 29.573      |
| its                    | Liters               | 0.473       |
| arts                   | Liters               | 0.946       |
| allons                 | Liters               | 3.785       |
| Ounces                 | Grams                | 28.349      |
| Pounds                 | Kilograms            | 0.454       |
| Short Tons             | Metric Tons          | 0.907       |
| Pound-Feet             | Newton-Meters        | 1.356       |
| Pounds per Square Inch | Kilopascals          | 6.895       |
| Miles per Gallon       | Kilometers per Liter | 0.425       |
| Miles per Hour         | Kilometers per Hour  | 1.609       |

| TO CHANGE          | TO                     | MULTIPLY BY |
|--------------------|------------------------|-------------|
| Centimeters        | Inches                 | 0.394       |
| Meters             | Feet                   | 3.280       |
| Meters             | Yards                  | 1.094       |
| Kilometers         | Miles                  | 0.621       |
| Square Centimeters | Square Inches          | 0.155       |
| Square Meters      | Square Feet            | 10.764      |
| Square Meters      | Square Yards           | 1.196       |
| Square Kilometers  | Square Miles           | 0.386       |
| Square Hectometers | Acres                  | 2.471       |
| Cubic Meters       | Cubic Feet             | 35.315      |
| Cubic Meters       | Cubic Yards            | 1.308       |
| Milliliters        | Fluid Ounces           | 0.034       |
| Liters             | Pints                  | 2.113       |
| Liters             | Quarts                 | 1.057       |
| ers                | Gallons                | 0.264       |
| ms                 | Ounces                 | 0.035       |
| ograms             | Pounds                 | 2.205       |
| Metric Tons        | Short Tons             | 1.102       |
| Newton-Meters      | Pounds-Feet            | 0.738       |
| Kilopascals        | Pounds per Square Inch | 0.145       |
| ometers per Liter  | Miles per Gallon       | 2.354       |
| ometers per Hour   | Miles per Hour         | 0.621       |

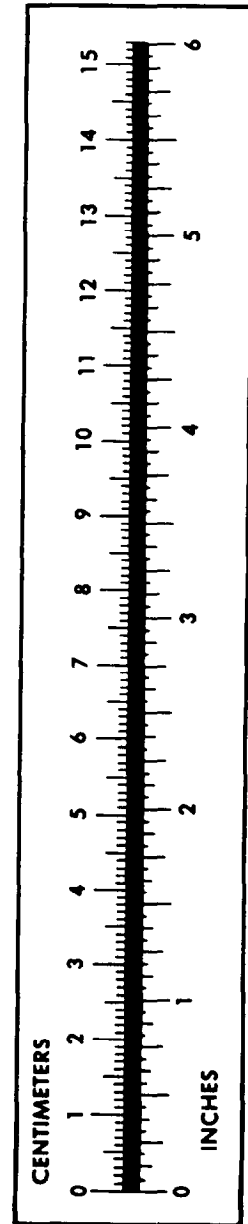

**PIN: 026255-005**